

## REPORT No. 706

### WIND-TUNNEL INVESTIGATION OF SPOILER, DEFLECTOR, AND SLOT LATERAL-CONTROL DEVICES ON WINGS WITH FULL-SPAN SPLIT AND SLOTTED FLAPS

By CARL J. WENZINGER and FRANCIS M. ROGALLO

#### SUMMARY

*An extensive investigation was made in the NACA 7- by 10-foot wind tunnel of spoiler, deflector, and slot types of lateral-control device on wings with full-span split and slotted flaps. The static rolling and yawing moments were determined for all the devices tested, and the static hinge moments and the time response were determined for a few devices of each type.*

*Spoilers alone on the wing upper surface were unsatisfactory unless located near the trailing edge. Deflectors (lower-surface devices) appeared to have insufficient power when operating alone but were beneficial in combination with spoilers. A slot between the spoiler and the deflector further increased their effectiveness, but the combinations tested did not have satisfactory hinge-moment characteristics. A plug-type spoiler-slot aileron appeared to be the most satisfactory device investigated for use with a full-span slotted flap.*

#### INTRODUCTION

The improved characteristics of high-lift devices and the high wing loadings of modern airplanes have indicated the need of employing such devices over the entire wing span to improve the take-off and the landing characteristics. If full-span trailing-edge high-lift devices are used, however, some lateral-control device other than the plain trailing-edge aileron becomes necessary. Many devices have been investigated by the NACA (reference 1), among which were a few arrangements suitable for application to wings with full-span high-lift devices. Up to the present time, none of these arrangements seems to have been accepted as generally satisfactory.

Several lateral-control devices of the spoiler type have been investigated by the NACA because spoilers permit the use of the entire trailing edge for flaps of various kinds. Some devices of this type have acceptable static characteristics on plain wings but are unsatisfactory because of an appreciable time delay between the movement of the control surface and the development of the resulting rolling moment. (See references 2 and 3.) This delay can be greatly reduced by means of a slot through the wing behind the spoiler

(reference 4). The increase in wing drag caused by a permanently open slot, however, generally prohibits its use on high-performance airplanes.

In the program of investigation leading to the development of a lateral-control device suitable for use with full-span high-lift devices, the NACA tested an arrangement comprising an articulated slot, a scoop, and a spoiler. This device had a much faster response than a simple spoiler in the same location and did not have the high drag usually associated with the permanently open slot. Some early British tests (reference 5) have also indicated that promising results might be obtained with combinations of an upper-surface spoiler, a scoop, and a slot through the wing.

The present investigation was undertaken for the purpose of developing a lateral-control device which could be used with any type of full-span trailing-edge high-lift device, which would be mechanically simple, and which would have better aerodynamic characteristics than devices previously tested. In this series of tests, the devices comprised various combinations of a simple upper-surface spoiler, a lower-surface flap or deflector, and a slot through the wing. The devices were tested at two locations on a Clark Y-15 wing with and without a full-span split flap and on an NACA 23012 wing with and without a full-span slotted flap. A plain sealed aileron was included as a basis for comparison.

The static rolling and yawing moments were determined for all the devices tested. The static hinge moments and the time response were determined for a few devices of each type.

#### APPARATUS AND METHODS

Two wing models were used in the investigation; one had the Clark Y-15 airfoil section and the other had the NACA 23012 section. The Clark Y-15 model was equipped with a full-span 20-percent-chord split flap and was essentially the same model used in the wind-tunnel tests reported in reference 4. The NACA 23012 model was equipped with a full-span 25.66-percent-chord slotted flap; the slot and the flap shapes and the flap positions were the same as for flap 2-h in reference 6.

Both models were as light in weight as practicable, the framework being of white pine and the covering of  $\frac{1}{8}$ -inch plywood. The chord of each model was 4 feet and the span 8 feet; all lateral-control devices had a 3-foot span and were built at the outboard end of the wing, as shown in figure 1. Cross sections of the models showing both high-lift and lateral-control devices are given in the figures that present the test results.

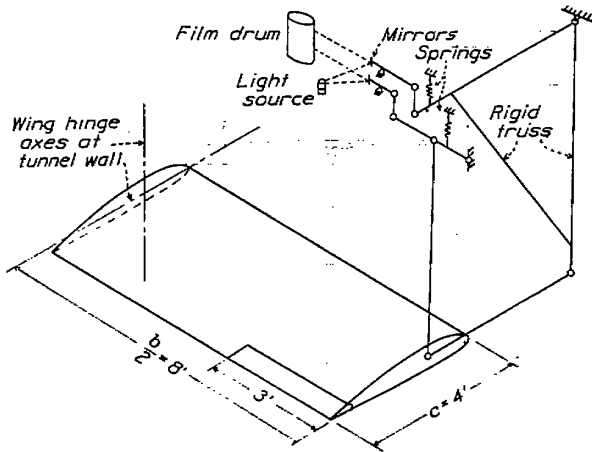
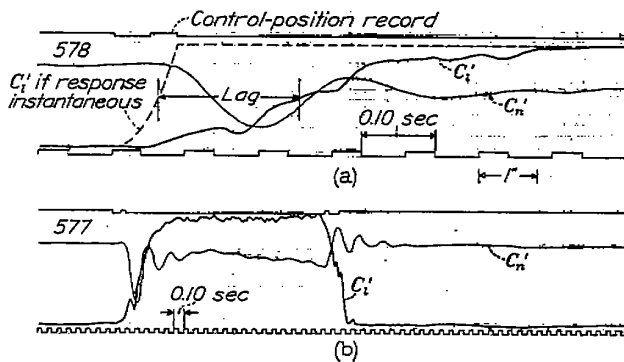

FIGURE 1.—Schematic diagram of test set-up. Span of all lateral-control devices, 3 feet.

All tests were made in the NACA 7- by 10-foot closed-throat wind tunnel (reference 6) at an air speed of 40 miles per hour, corresponding to an effective Reynolds number of approximately two millions. The test set-up is schematically shown in figure 1. The model was suspended horizontally in the wind tunnel with one end adjoining the tunnel wall so as to simulate the semispan of a 16-foot wing. The outboard section, in which the lateral-control devices were installed, cleared one vertical wall of the tunnel by 2 feet. The inboard end of the model was fastened to the other vertical wall of the tunnel in such a manner that it was not restrained either in roll or in yaw. The restraining moments were applied at a pin joint at the outboard end of the model through linkages, as shown in



(a) High-speed record.  
(b) Low-speed record.

FIGURE 2.—Typical time-history records.

figure 1, which permitted the rolling and the yawing moments to be determined.

The lateral-control devices were manually operated by cranks outside the tunnel wall next to the inboard end of the model; these cranks were connected to the various devices by means of torque rods and suitable linkages. Hinge moments were determined by means of calibrated torque rods.

The principle of the force-recording mechanism is shown in figure 1. The rolling and the yawing moments were resisted by springs, the deflections of which were photographically recorded on a revolving film. Plotted values from typical records are shown in figure 2. The control-position record, which appears above the rolling- and the yawing-moment records in figure 2, was obtained by means of a group of electrical contacts in series with a solenoid that deflected a mirror similar to the mirrors shown in figure 1. From the known positions of the electrical contacts relative to the deflection of each control device, curves of control position against time could be constructed. Control-position curves are not drawn in figure 2, but the corresponding curve of static rolling-moment coefficient is given as a broken line in figure 2 (a). This broken line represents the time history that would have been obtained if there were no delay in the development of the rolling moment. The lag is defined as the horizontal distance between this constructed curve and the actual curve of  $C_i'$  at one-half the final value.

## RESULTS AND DISCUSSION

### SYMBOLS AND CONVENTIONS

In the presentation of results, the following symbols are used:

$C_L$  lift coefficient ( $L/qS$ )

$C_i'$  rolling-moment coefficient ( $L'/qbS$ )

$C_n'$  yawing-moment coefficient ( $N'/qbS$ )

$H$  hinge moment in inch-pounds at 40 miles per hour

$L$  twice the lift on the half-span model

$S$  twice the area of the half-span model

$b$  twice the span of the half-span model

$c$  airfoil chord

$L'$  rolling moment about wind axis

$N'$  yawing moment about wind axis

$q$  dynamic pressure of air stream

$\delta_f$  flap deflection

A positive value of  $L'$  or  $C_i'$  corresponds to a decrease in lift on the model and a positive value of  $N'$  or  $C_n'$  corresponds to an increase in drag on the model. Twice the actual lift, area, and span of the model were used in the reduction of results because the model represents half of a complete wing. No corrections have been made for the effect of the tunnel walls. These corrections might be relatively large for the type of test installation used in this investigation.

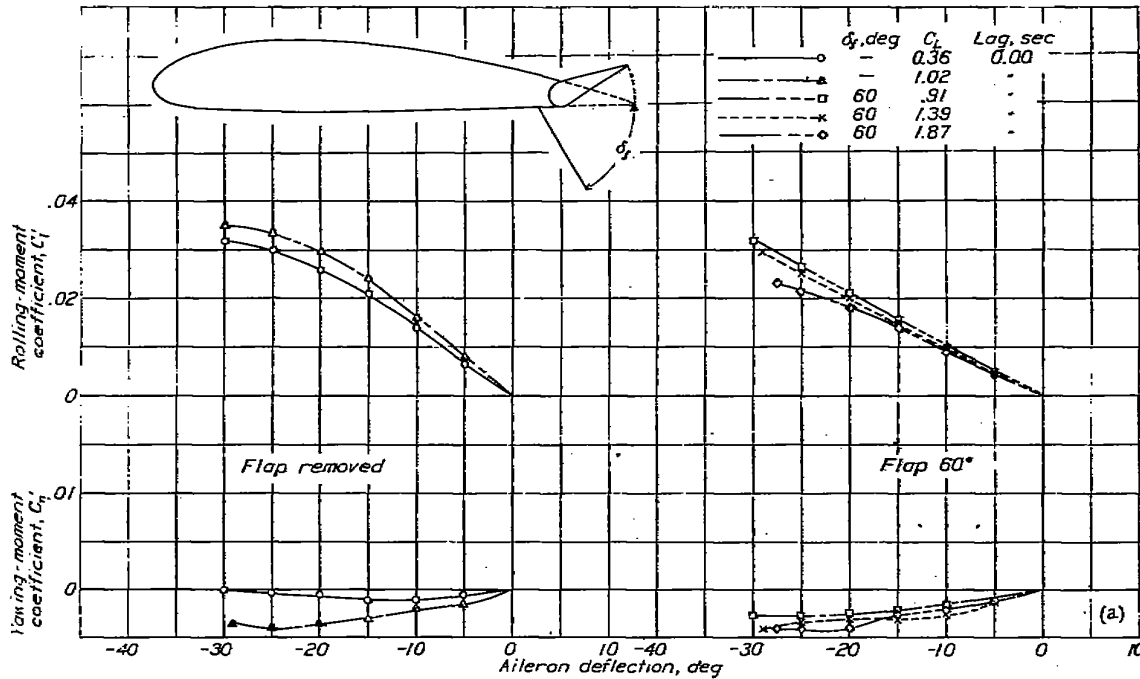

(a) Rolling- and yawing-moment coefficients.

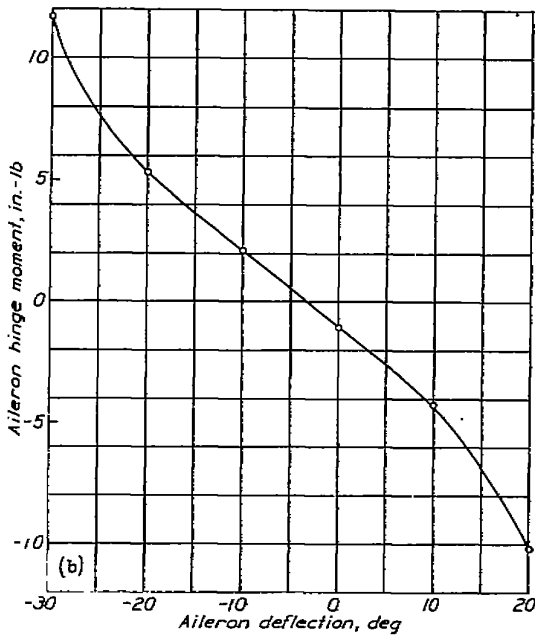

(b) Hinge moment at 40 miles per hour; split flap removed;  $C_L = 0.36$ .  
 FIGURE 3.—A 0.15c plain sealed aileron on a Clark Y-15 wing with and without a 0.20c full-span split flap.

In the presentation of results for the plain sealed aileron and the spoiler-slot aileron, a positive deflection is one in the direction of increasing angle of pitch. For the spoilers and the deflectors, a positive projection is a projection out of the wing surface and is measured perpendicularly to the surface. Hinge moments of spoilers and deflectors are arbitrarily taken as positive when they resist a positive projection of the device.

All rolling-, yawing-, and hinge-moment data are given for a device on only one wing tip. To estimate the effects of a device at each tip of a wing would necessitate a knowledge of the details of the linkage between the two.

PLAIN AILERONS

The results of tests of the plain aileron (split flap removed) are presented in the left-hand portion of figure 3 (a). The results in the right-hand portion of the figure were obtained with the full-span flap in place, as shown in the sketch. With the flap in place, that is, deflected 60°, the rolling moments decreased with increasing lift coefficient. The yawing moments were adverse at all test conditions. The lag was too small to be measured. The aileron hinge moment at  $C_L = 0.36$  with flap removed is given in figure 3 (b).

SPOILERS

Flap type.—Rolling- and yawing-moment coefficients are given in figures 4 and 5 for plain flap-type spoilers on wings with both split and slotted flaps. These spoilers were ineffective in producing rolling moment until projected a considerable portion of their range. It should be noted that this type of device, in general, increases in effectiveness with increase in lift coefficient of the wing with flap either neutral or deflected. Yawing moments were usually positive, or favorable. Rearward movement of the location of the spoilers generally decreased the lag, reduced the ineffective region near neutral, and decreased the magnitude of the favorable yawing moments. Hinge-moment characteristics of the spoiler in the rear location on the wing with the slotted flap are shown in figure 5 (c).

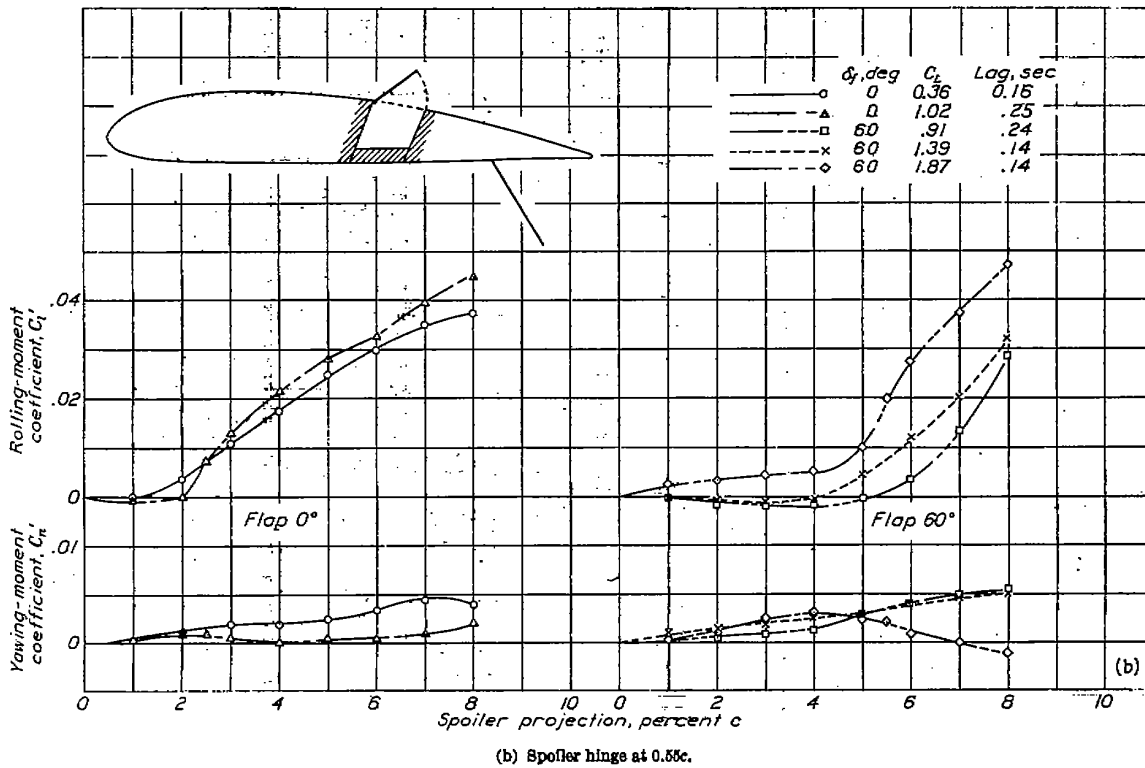
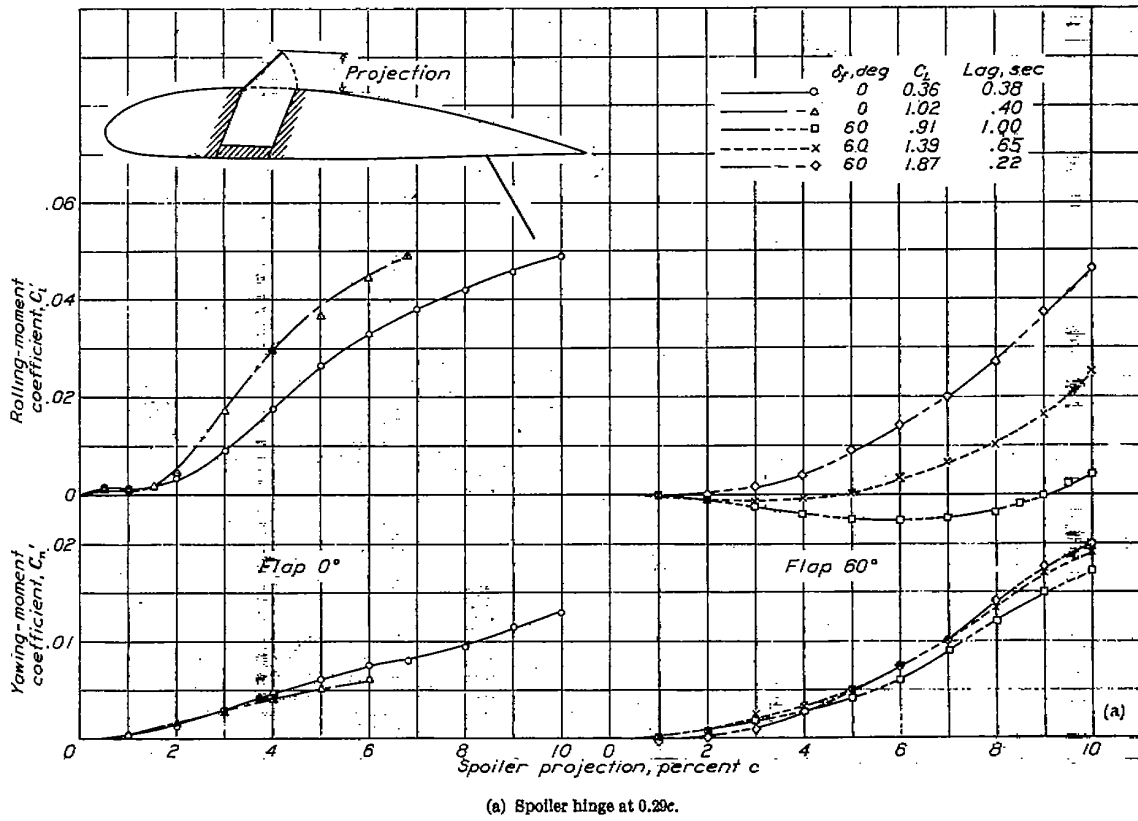
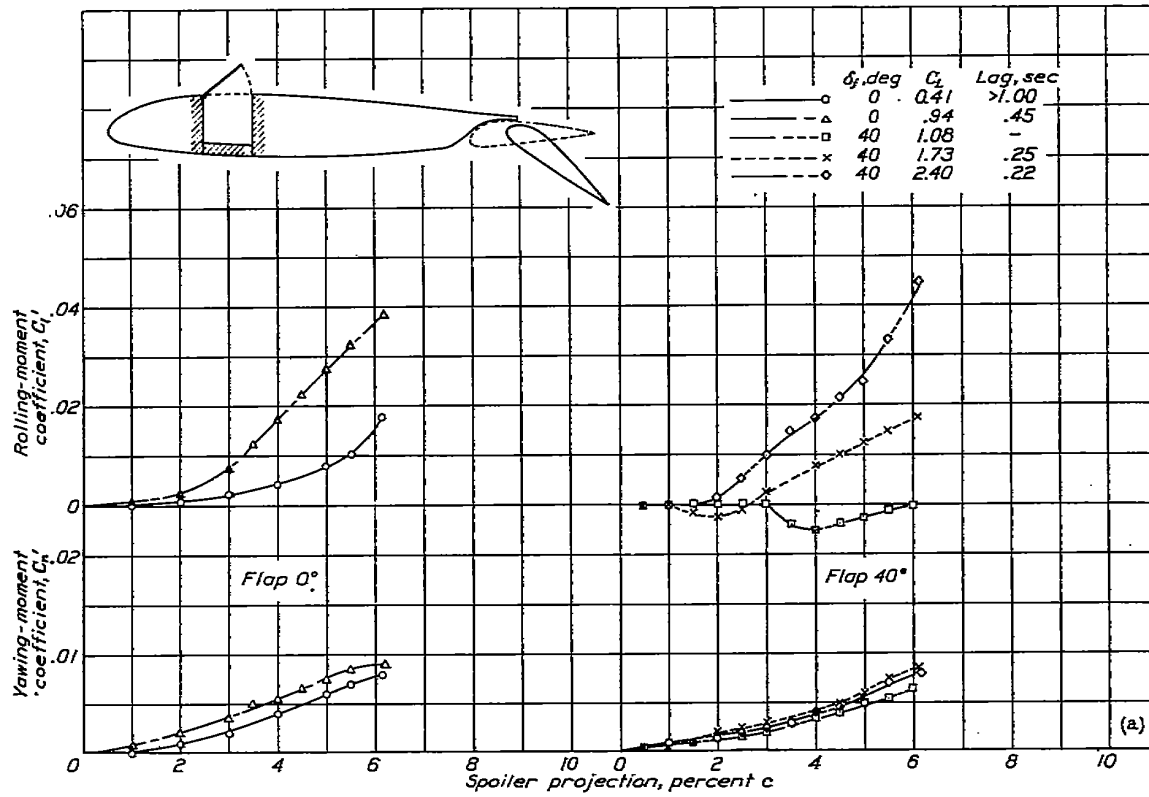
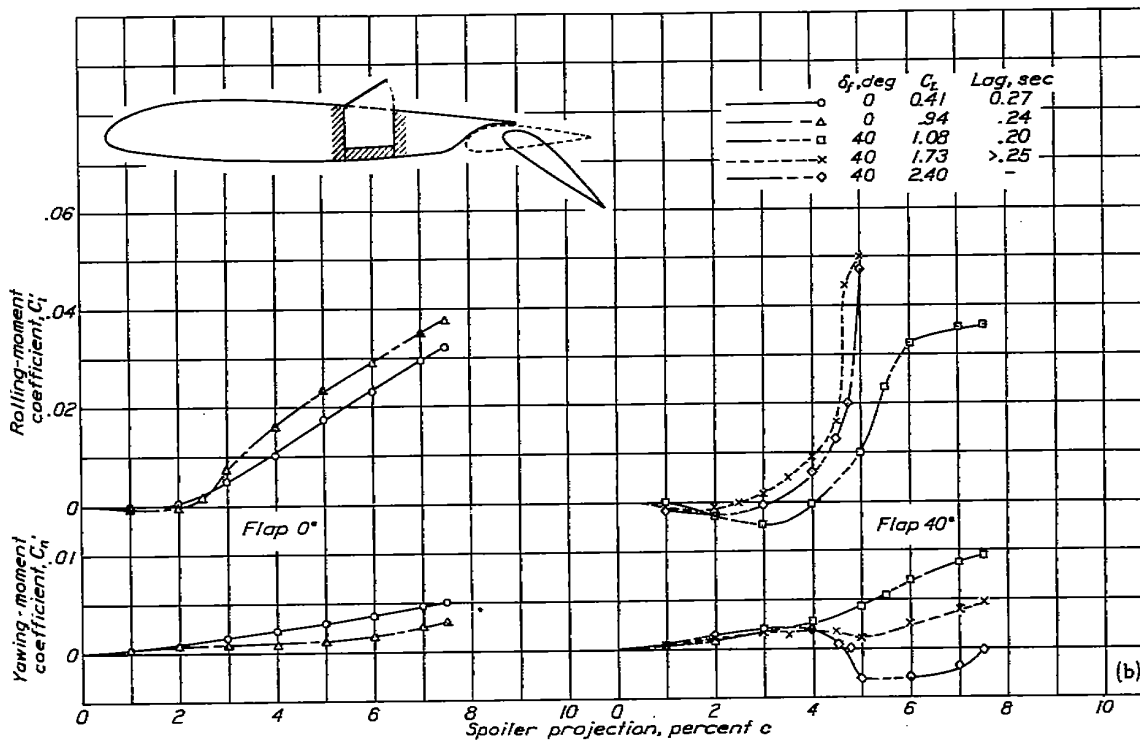

FIGURE 4.—Rolling- and yawing-moment coefficients due to an 0.11c spoiler on a Clark Y-15 wing with a 0.20c full-span split flap.



(a) Rolling- and yawing-moment coefficients; spoiler hinge at 0.20c.



(b) Rolling and yawing-moment coefficients; spoiler hinge at 0.50c.

FIGURE 5.

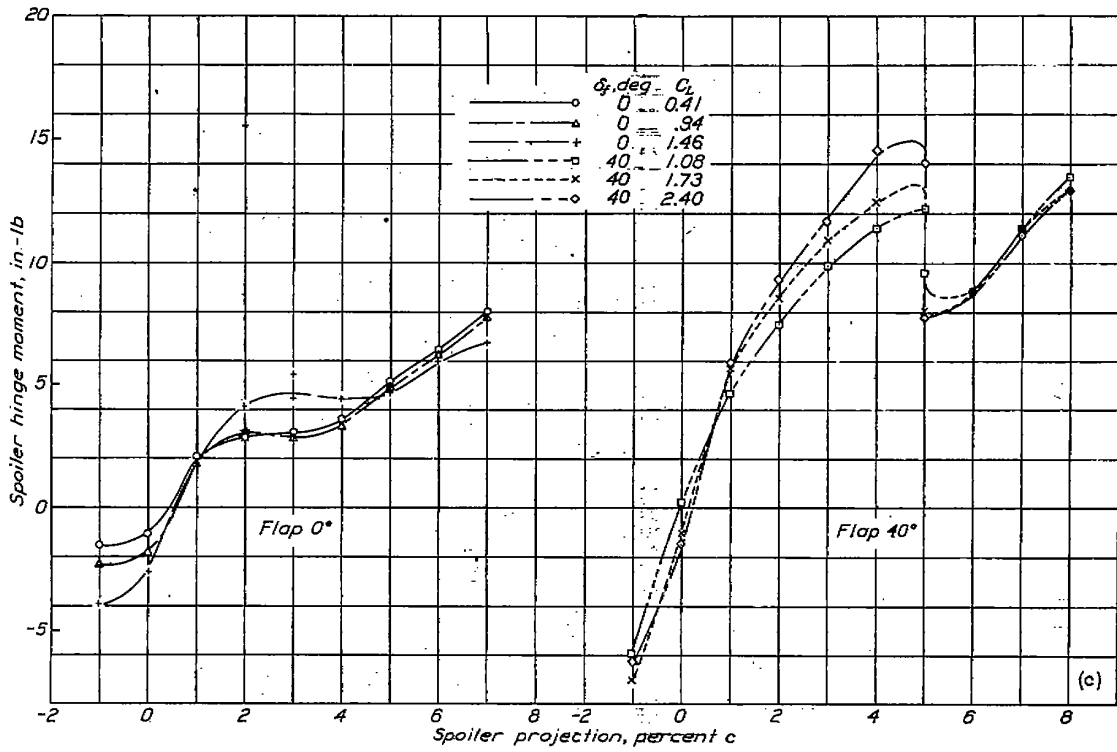

(c) Hinge moment at 40 miles per hour; spoiler hinge at  $0.60c$ .  
 FIGURE 5.—A  $0.10c$  spoiler on an NACA 23012 wing with a  $0.266c$  full-span slotted flap.

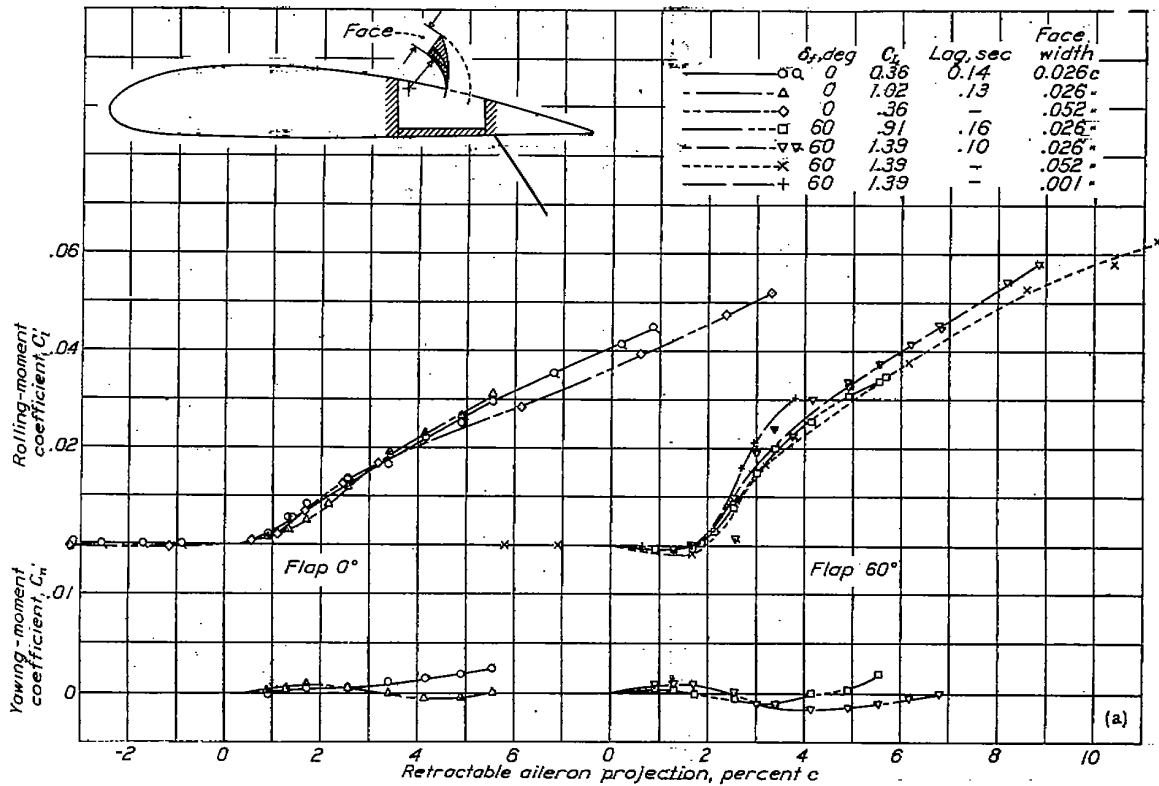

(a) Rolling- and yawing-moment coefficients.

FIGURE 6.

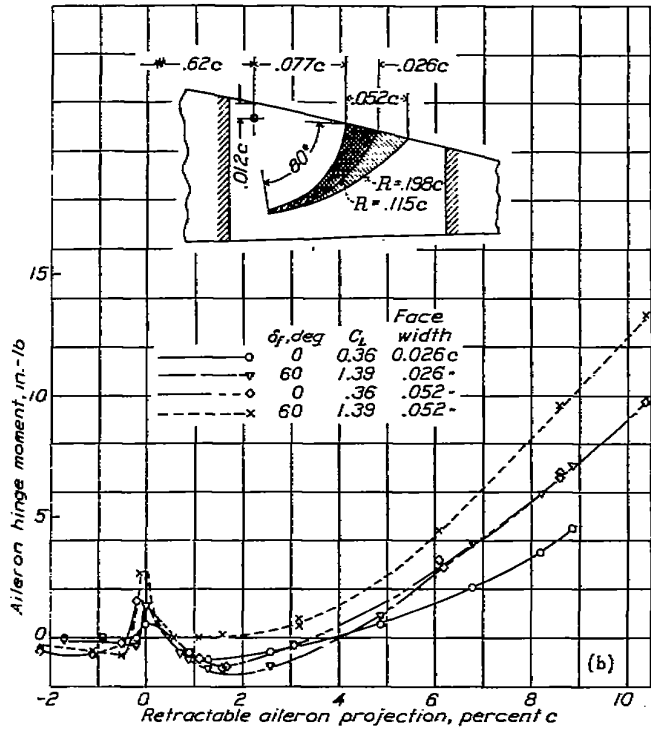

(b) Hinge moment at 40 miles per hour.  
 FIGURE 6.—A retractable aileron on a Clark Y-15 wing with a 0.20c full-span split flap.

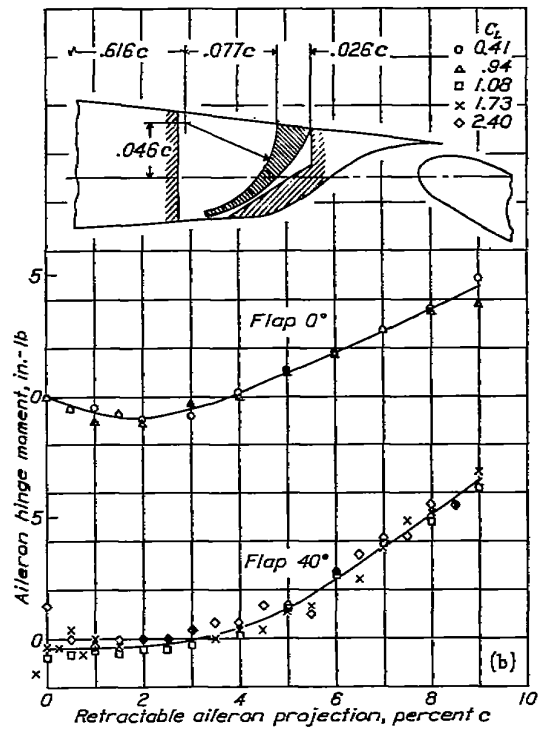

(b) Hinge moment at 40 miles per hour.  
 FIGURE 7.—A retractable aileron on an NACA 23012 wing with a 0.2566c full-span slotted flap.

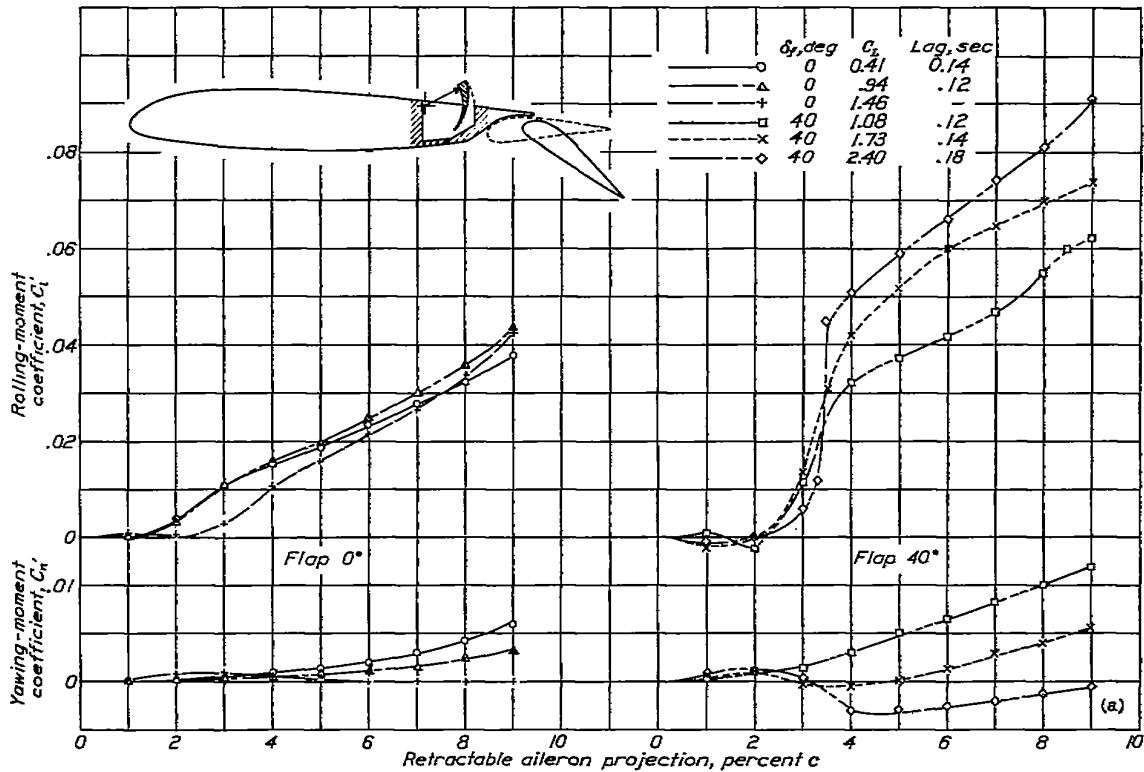

(a) Rolling- and yawing-moment coefficients.

FIGURE 7.

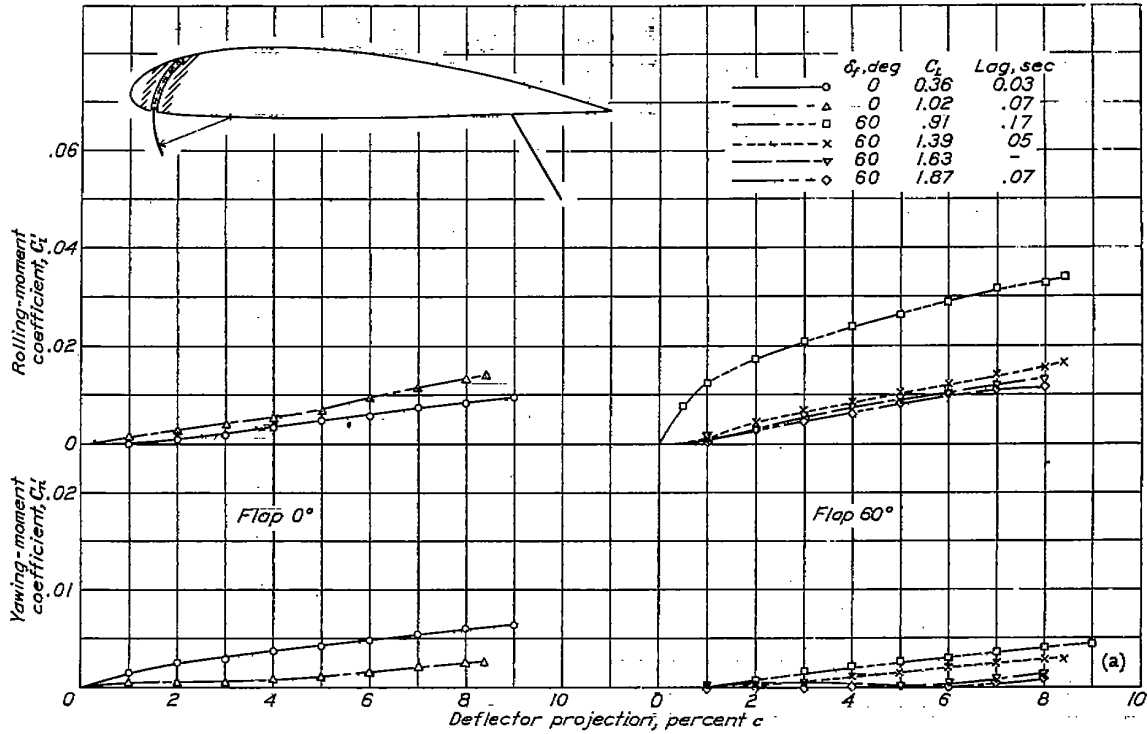

(a) Retractable deflector at 0.05c.

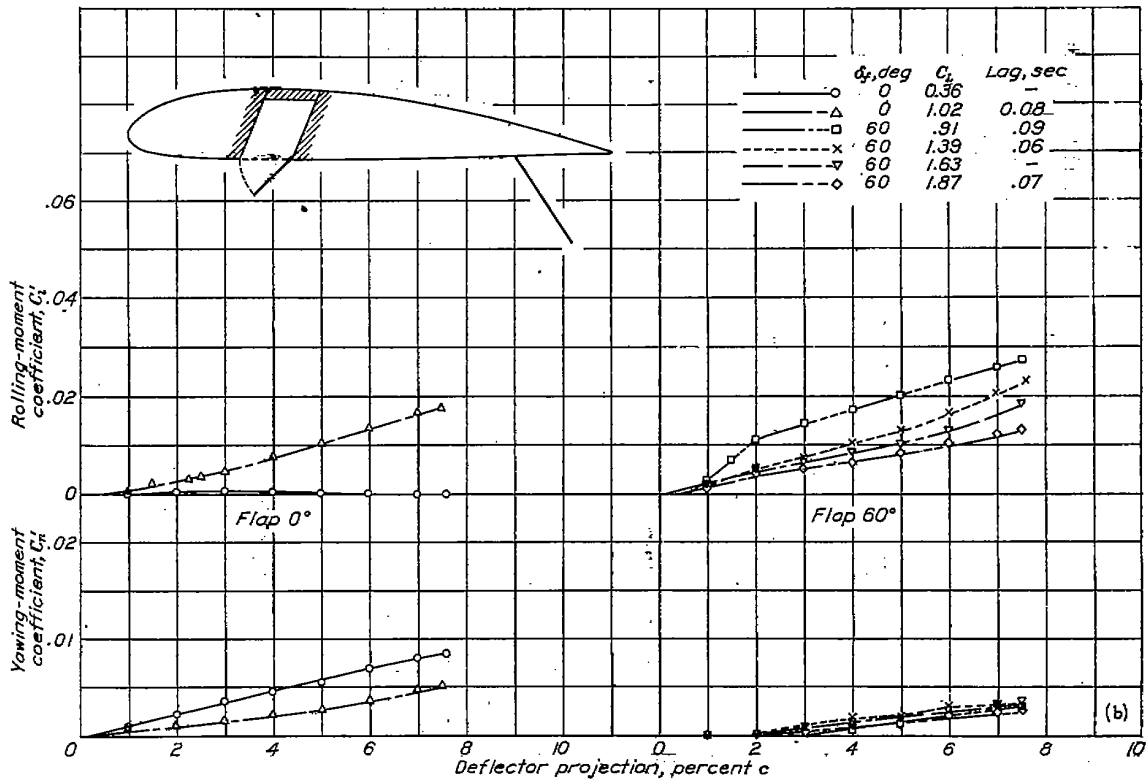

(b) An 0.11c deflector hinged at 0.34c.

FIGURE 8.



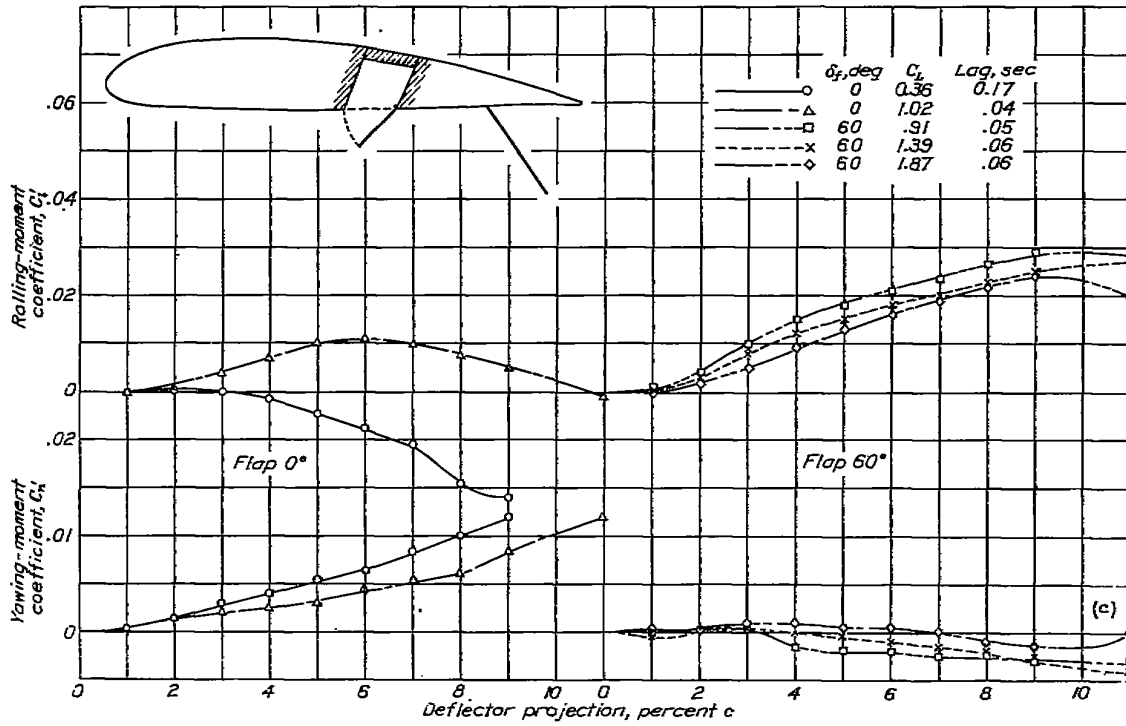

(c) An 0.11c deflector hinged at 0.61c.

FIGURE 8.—Rolling- and yawing-moment coefficients due to a deflector on a Clark Y-15 wing with a 0.20c full-span split flap.

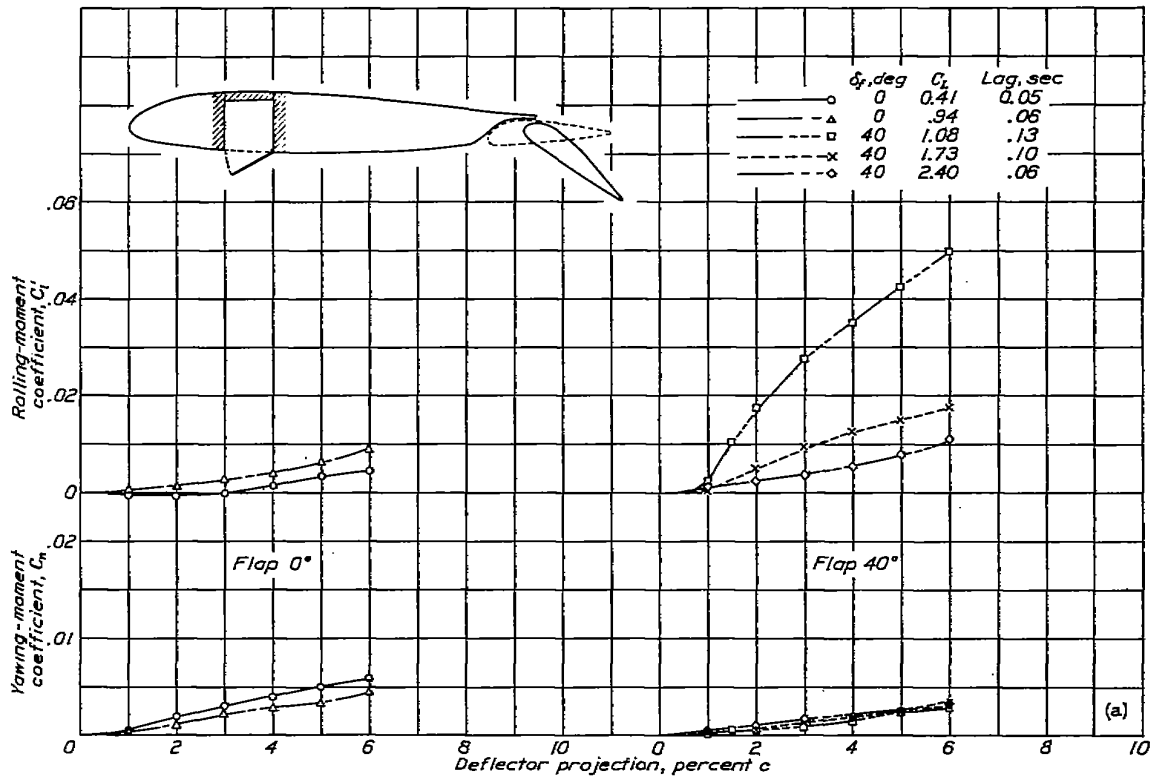

(a) Rolling- and yawing-moment coefficients; deflector hinge at 0.30c.

FIGURE 9.

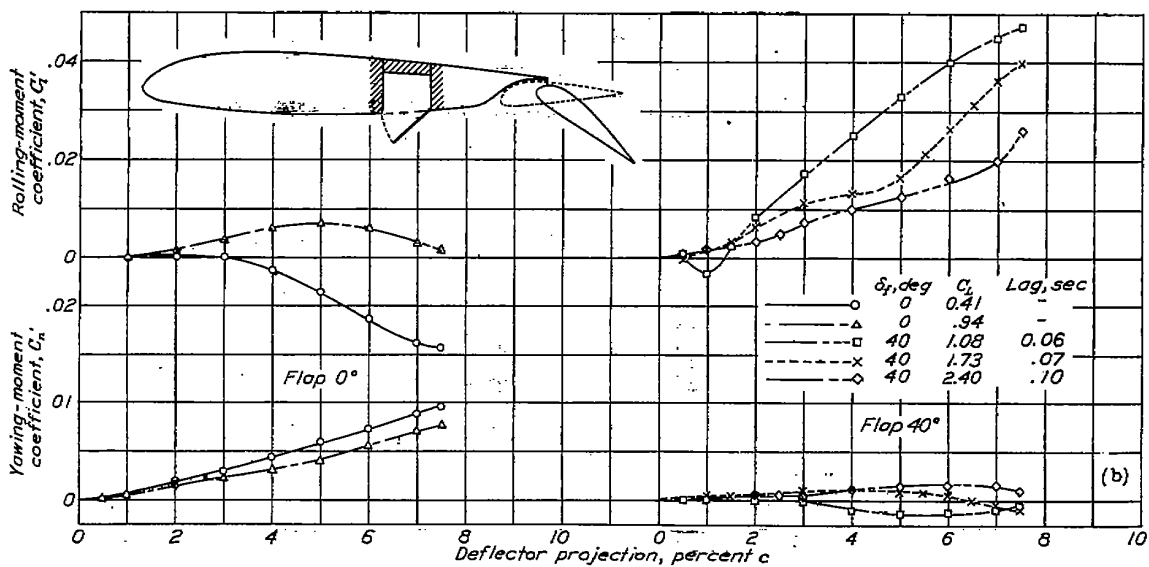

(b) Rolling- and yawing-moment coefficients; deflector hinge at  $0.60c$ .

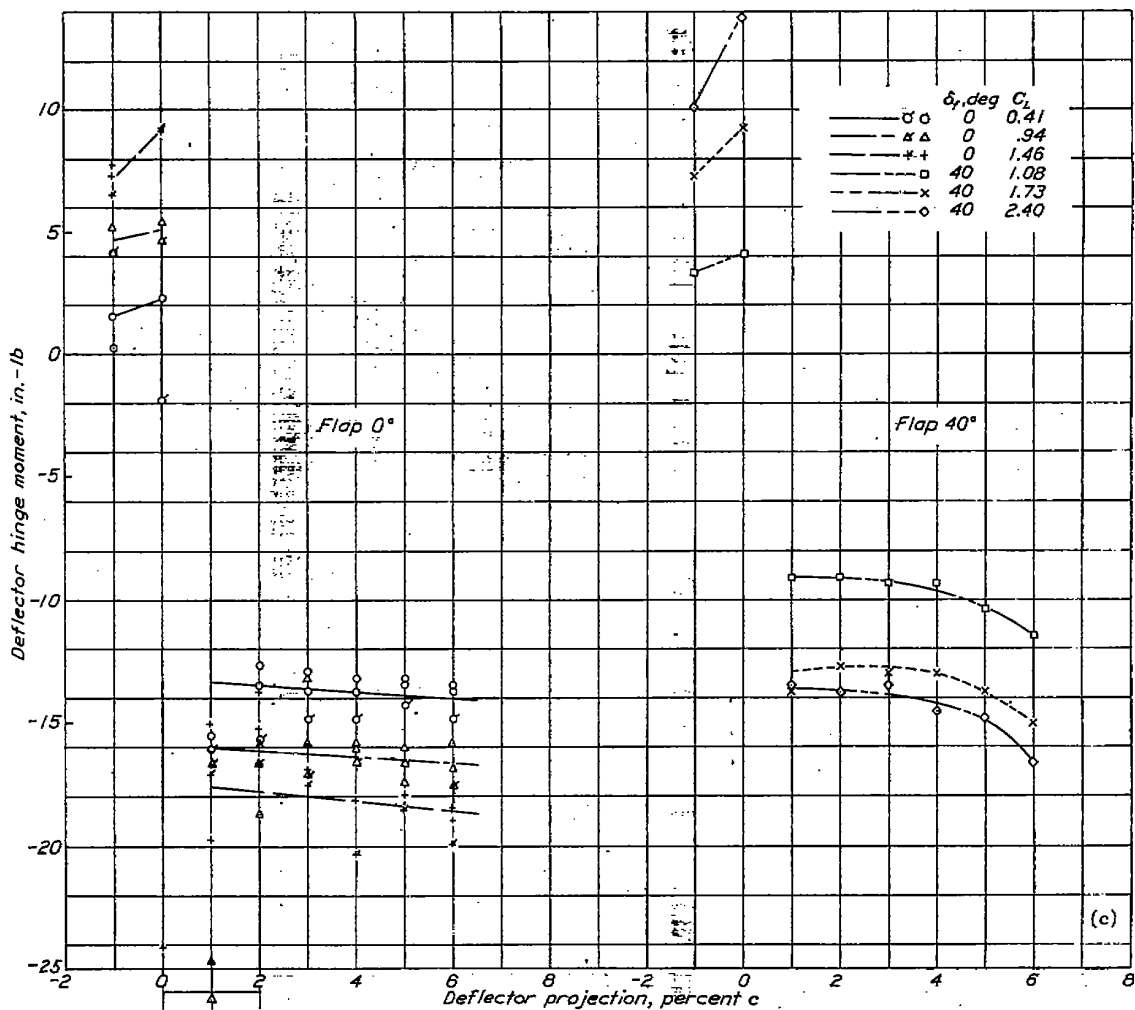

(c) Hinge moment at 40 miles per hour; deflector hinge at  $0.60c$ .

FIGURE 9.—A  $0.10c$  deflector on an NACA 23012 wing with a  $0.256c$  full-span slotted flap.

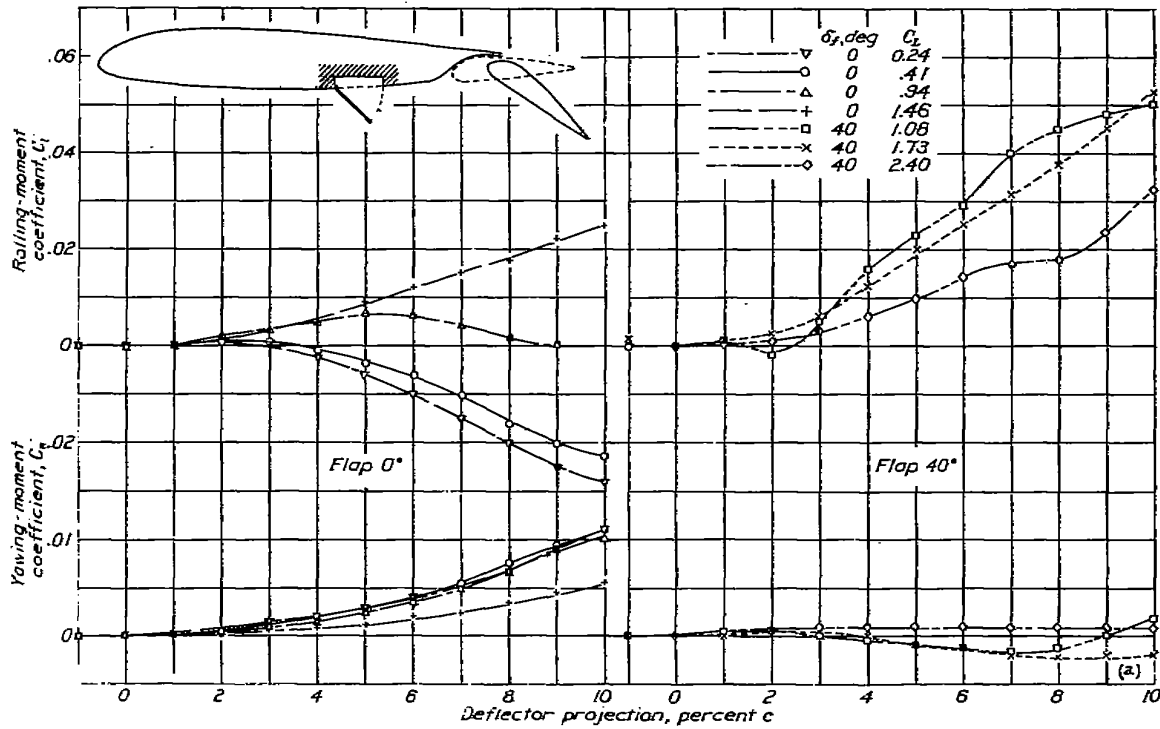

(a) Rolling- and yawing-moment coefficients.

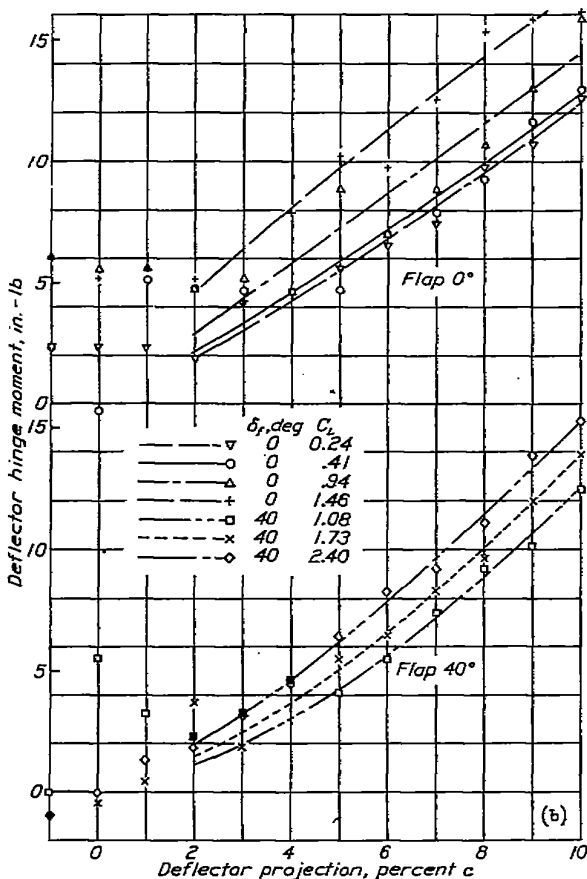

(b) Hinge moment at 40 miles per hour.

FIGURE 10.—A 0.10c deflector hinged at 0.50c on an NACA 23012 wing with a 0.2566c full-span slotted flap.

**Retractable ailerons.**—The characteristics of retractable ailerons, which are retractable spoilers located near the wing trailing edge, are shown in figures 6 and 7. On the wing with the split flap deflected, the retractable aileron was not effective until it projected 0.02c above the wing surface. This region of ineffectiveness was independent of the face width of the device. A tuft study showed that the air flow was returning to the surface of the wing behind the spoiler at low projections but that the point of return moved back as the projection increased. The device became effective when this point reached the wing trailing edge.

On the wing with the slotted flap deflected  $40^\circ$ , the rolling moment increased very rapidly when the aileron was projected about 0.03c, as shown in figure 7.

The hinge-moment characteristics of the retractable ailerons on the wings with the two types of flap were similar. The characteristics for the wing with the slotted flap (fig. 7 (b)) appeared to be slightly better than those for the wing with the split flap (fig. 6 (b)). The hinge moments of this device could probably be made satisfactory by reducing the face width to a thin edge and by moving the top of the aileron somewhat to the rear so that a cross section is no longer a true arc about the hinge point. Such an arrangement, however, requires a considerable opening in the wing surface when the aileron is neutral, thereby leading to an adverse effect on the wing drag.

The spoilers, in general, had excessive lag, but the lag decreased as the location of the device was moved back. The lag of the retractable aileron may be acceptable.

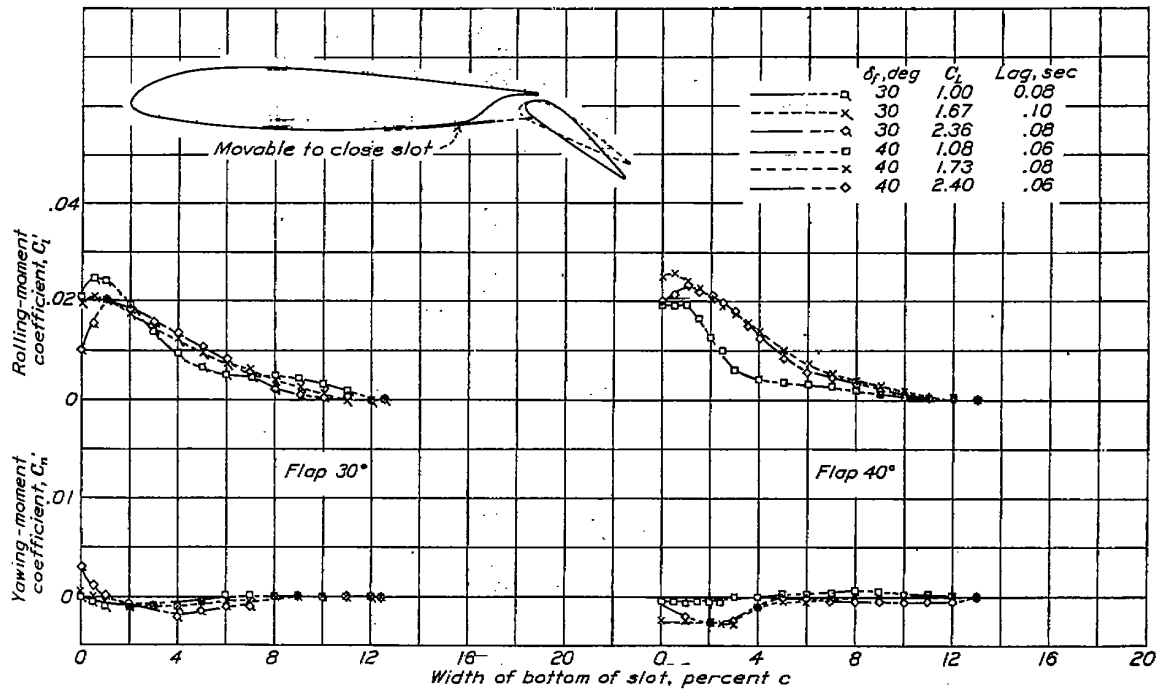
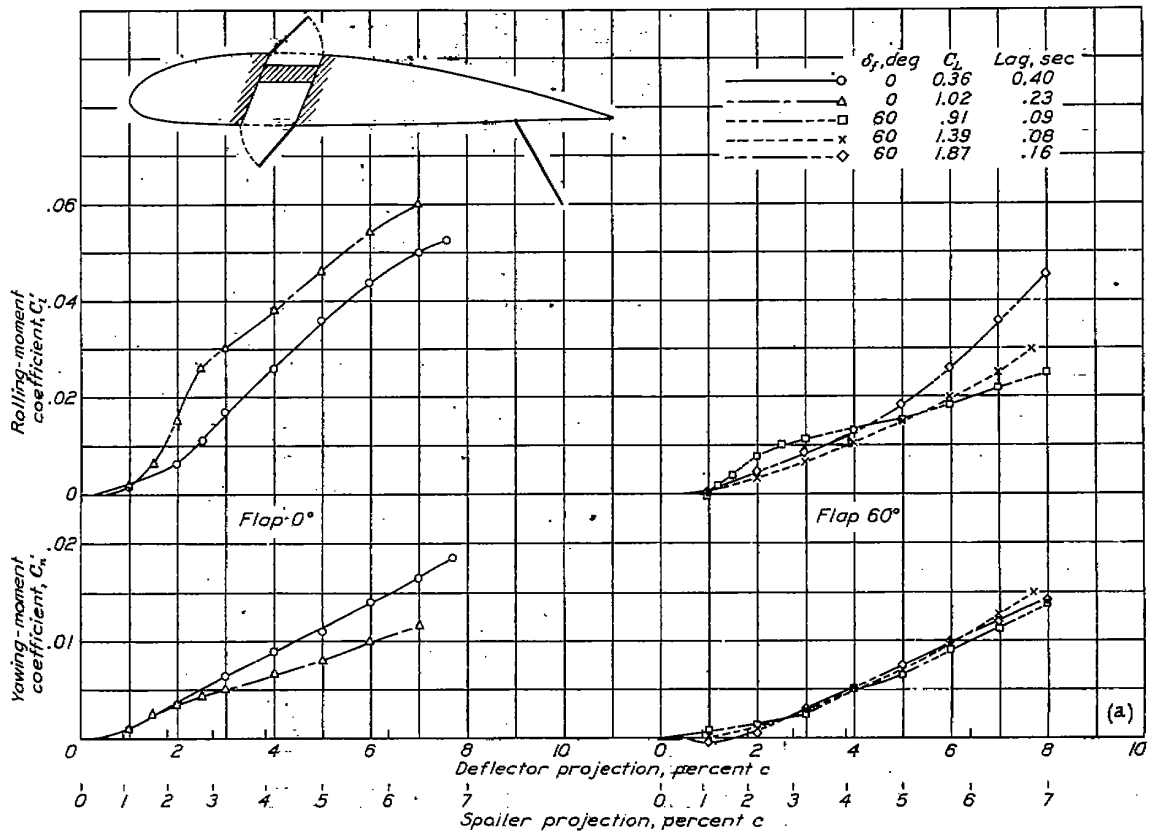
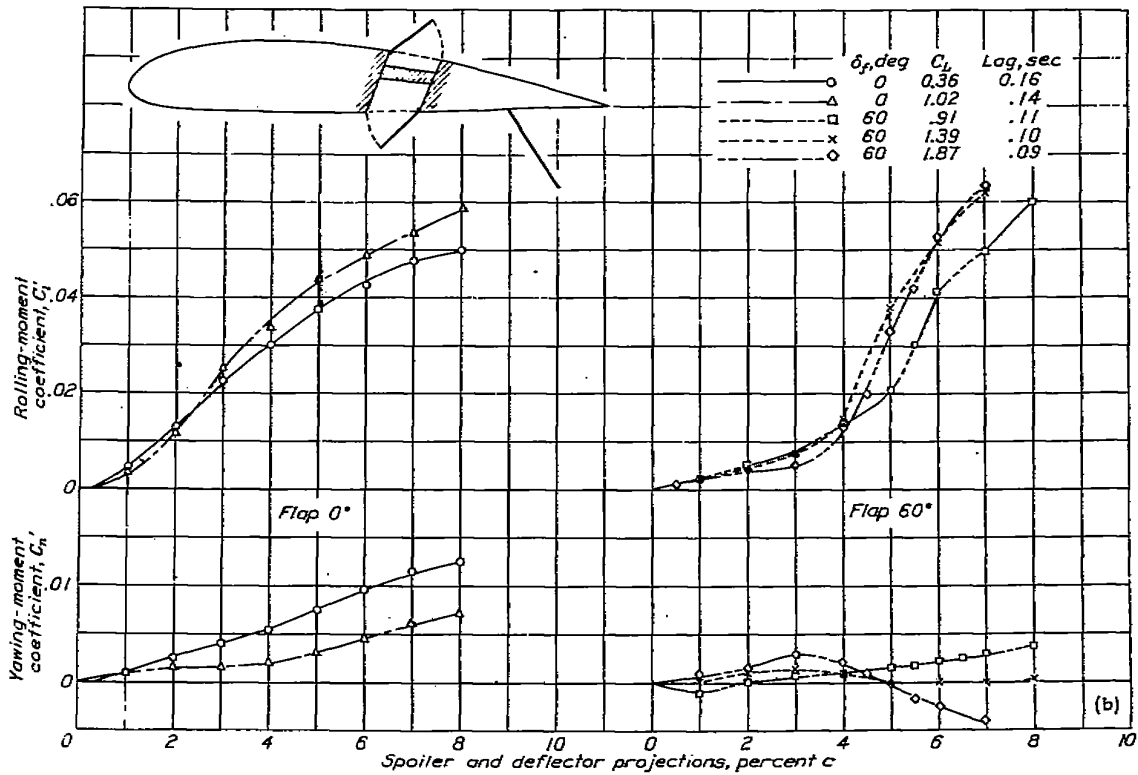

FIGURE 11.—Rolling- and yawing-moment coefficients due to a slot-closing deflector on an NACA 23012 wing with a 0.2568c full-span slotted flap.



(a) Spoiler hinge at 0.29c; deflector hinges at 0.34c.

FIGURE 12.



(b) Spoiler hinge at 0.55c; deflector hinge at 0.61c.

FIGURE 12.—Rolling- and yawing-moment coefficients due to an 0.11c spoiler and an 0.11c deflector on a Clark Y-15 wing with a 0.20c full-span split flap.

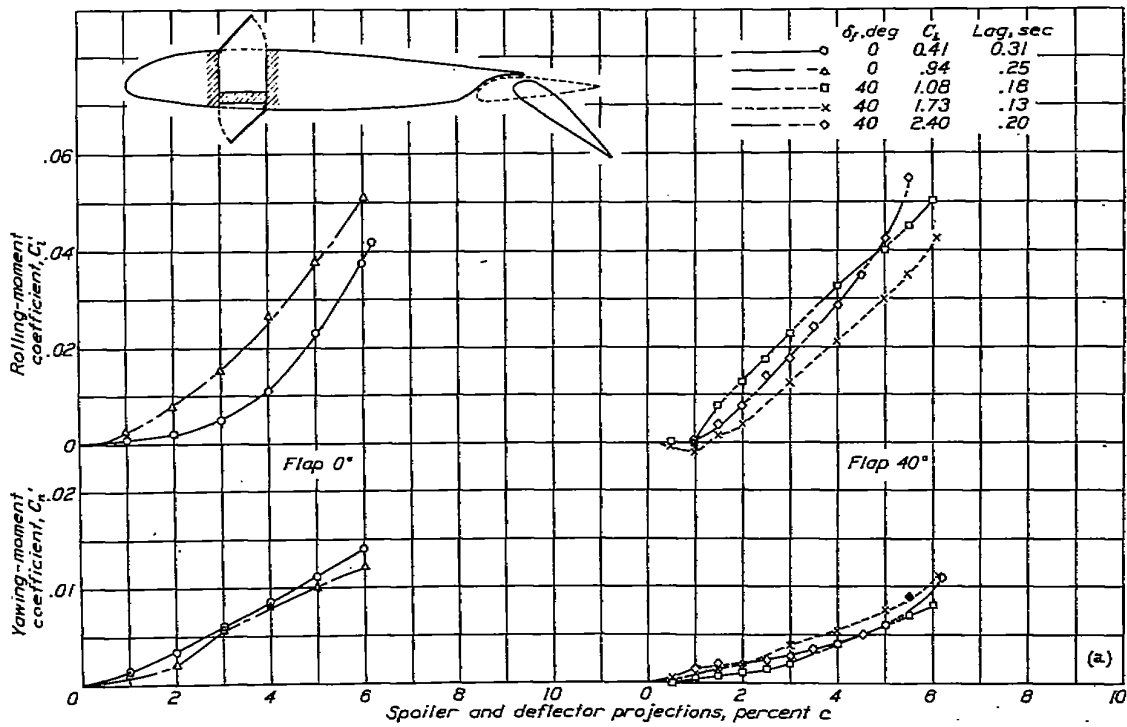

(a) Spoiler hinge at 0.20c; deflector hinge at 0.30c.

FIGURE 13.

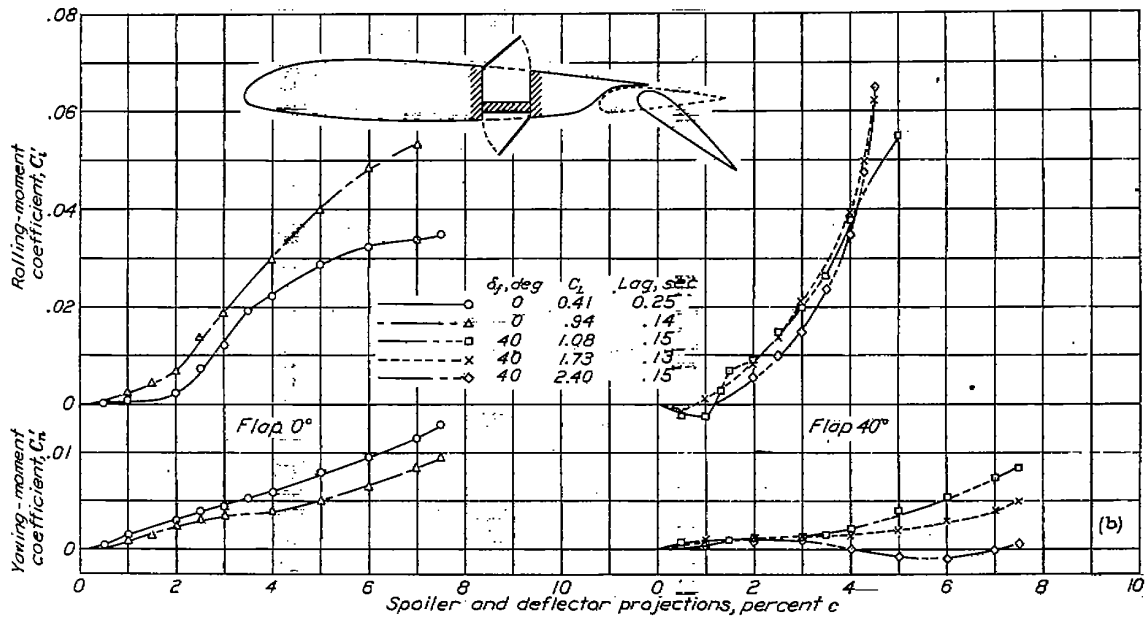

(b) Spoiler hinge at 0.50c; deflector hinge at 0.60c.

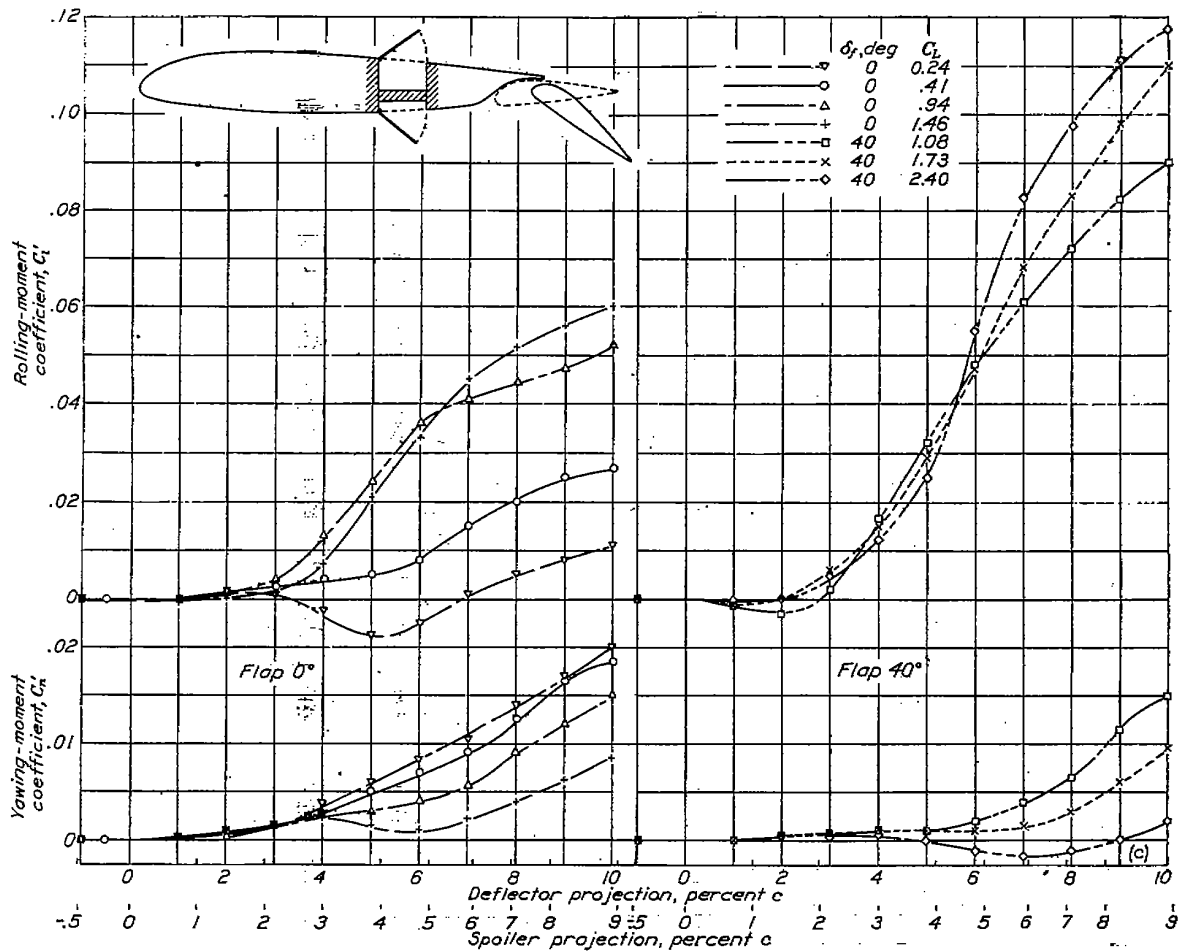

(c) Spoiler hinge at 0.50c; deflector hinge at 0.50c.

FIGURE 13.—Rolling- and yawing-moment coefficients due to a 0.10c spoiler and a 0.10c deflector on an NACA 23012 wing with a 0.256c full-span slotted flap.

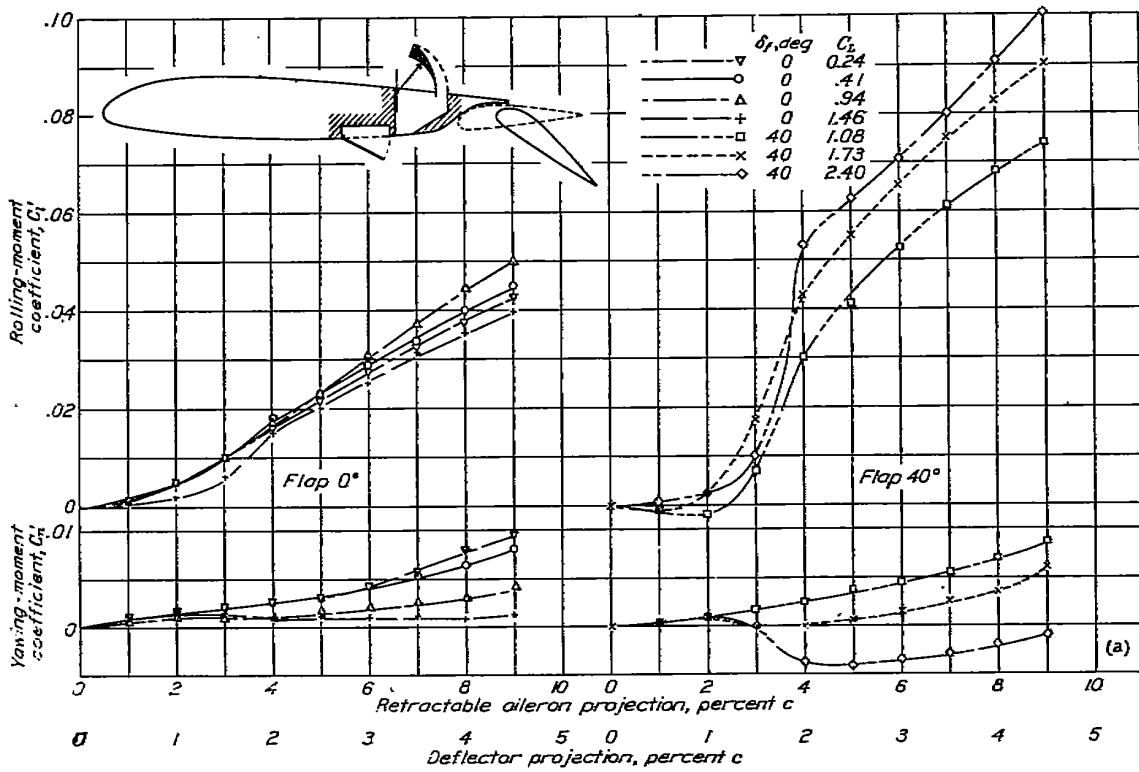

(a) Projection ratio of aileron to deflector, 2:1.

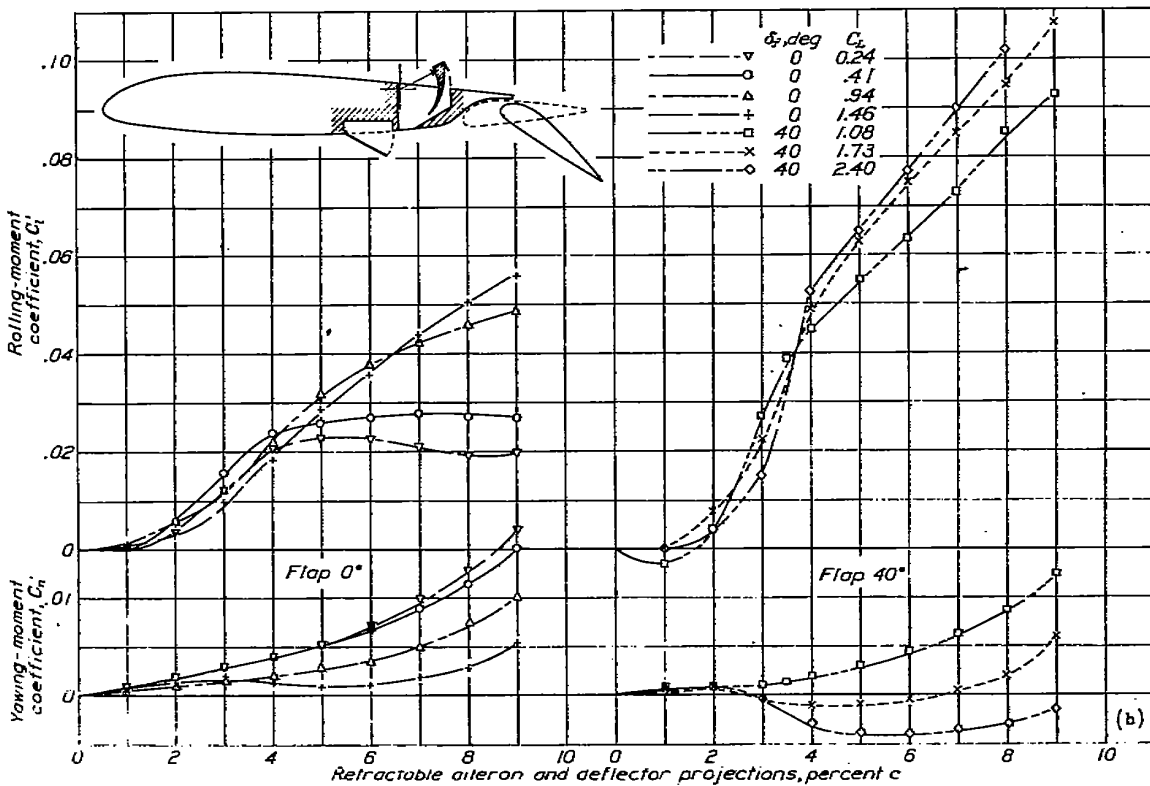

(b) Projection ratio of aileron to deflector, 1:1.

FIGURE 14.

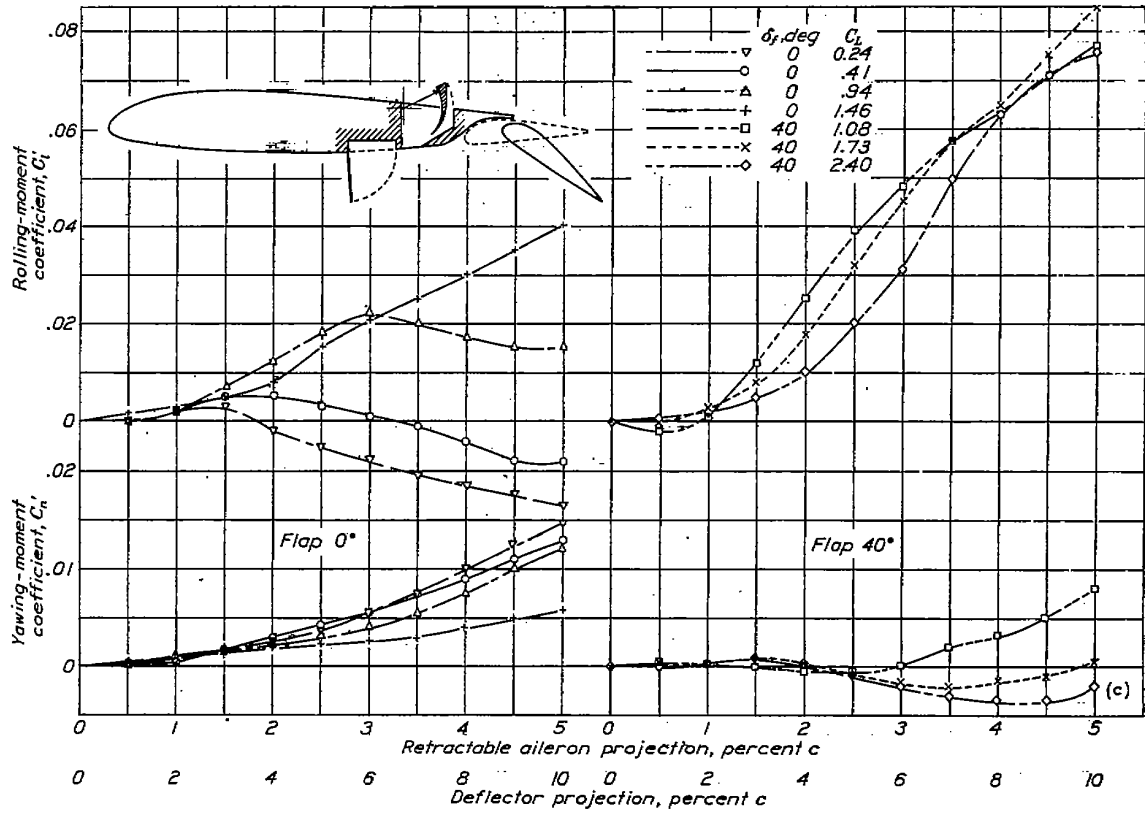

(c) Projection ratio of aileron to deflector, 1:2.

FIGURE 14.—Rolling and yawing-moment coefficients due to a 0.10c deflector hinged at 0.80c and a retractable aileron on an NACA 23012 wing with a 0.2560c full-span slotted flap.

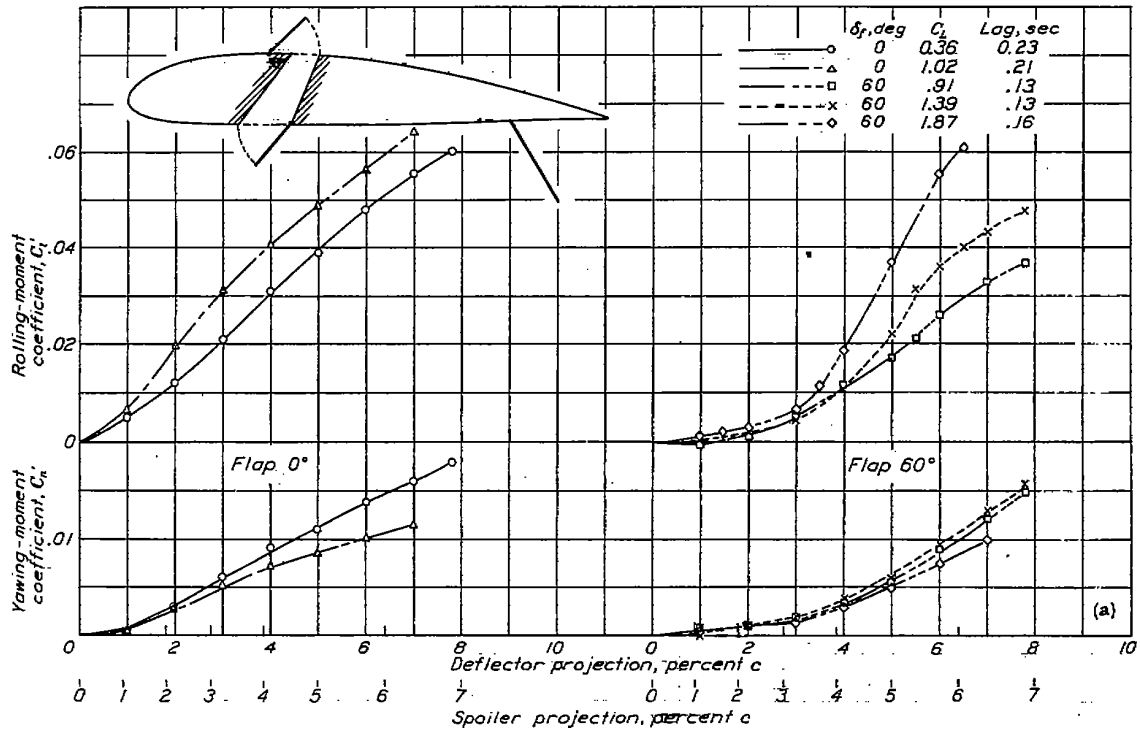

(a) Spoiler hinge at 0.23c; deflector hinge at 0.34c; slot width at top, 0.06c.

FIGURE 15.



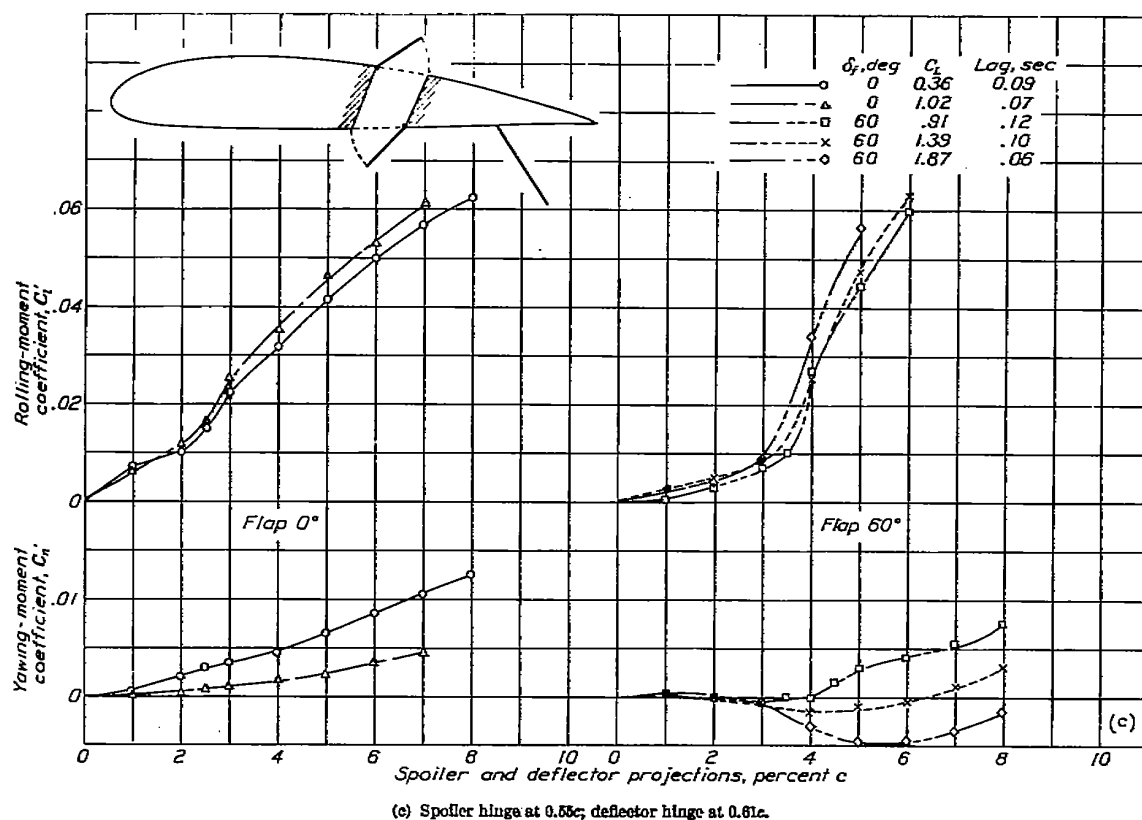
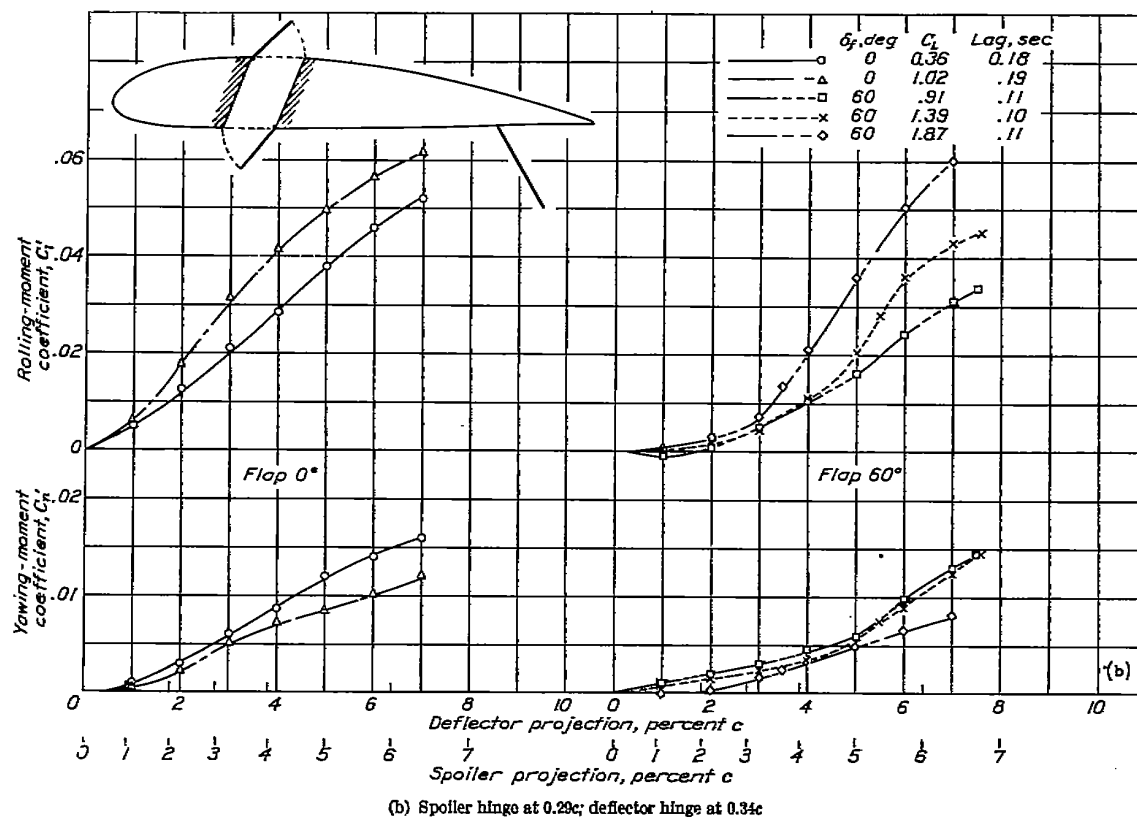
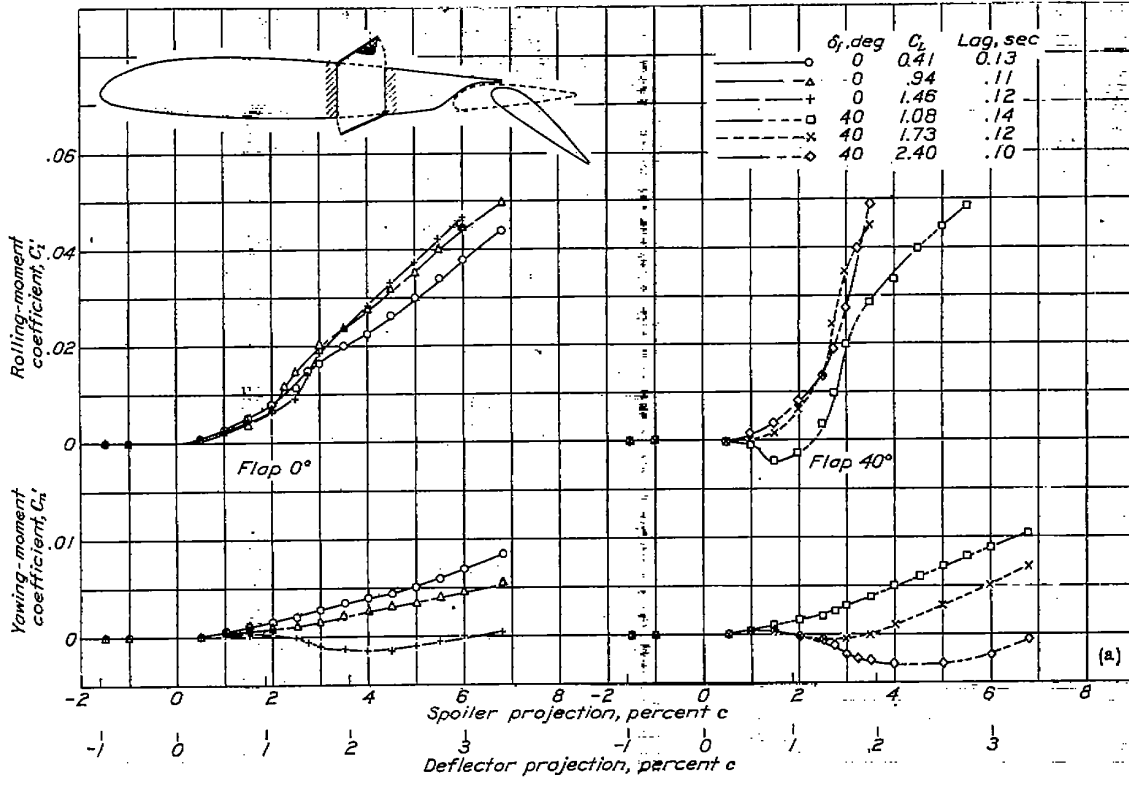
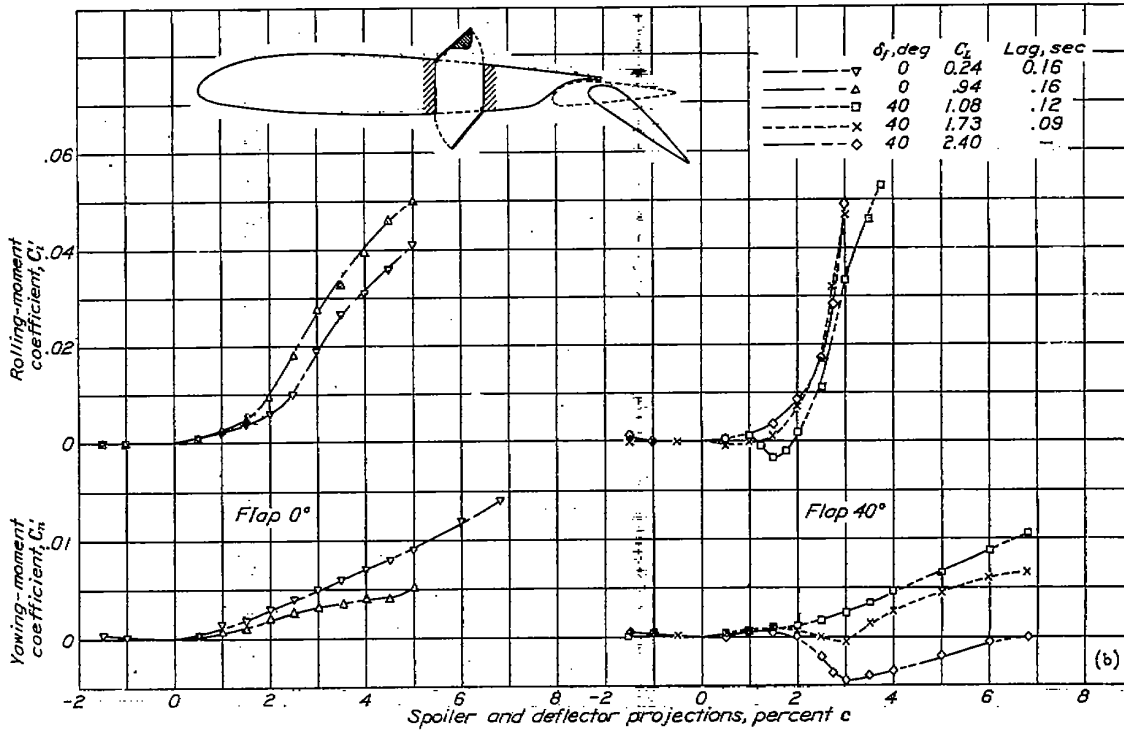

FIGURE 15.—Rolling- and yawing-moment coefficients due to an 0.11c spoiler and an 0.11c deflector with a slot on a Clark Y-15 wing with a 0.20c full-span split flap.



(a) Projection ratio of spoiler to deflector, 2:1.



(b) Projection ratio of spoiler to deflector, 1:1.

FIGURE 16.

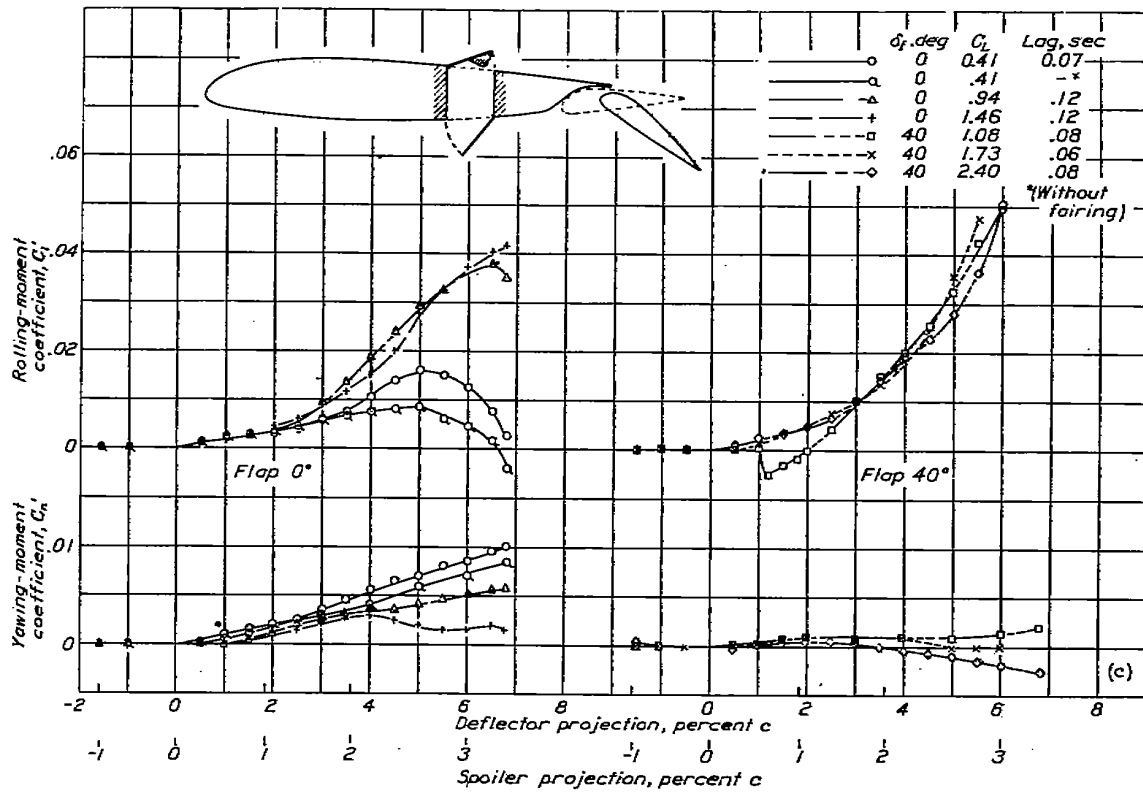

(c) Projection ratio of spoiler to deflector, 1:2.

FIGURE 16.—Rolling- and yawing-moment coefficients due to a 0.10c faired spoiler hinged at 0.60c and a 0.10c deflector hinged at 0.60c with a slot on an NACA 23012 wing with a 0.2560c full-span slotted flap.

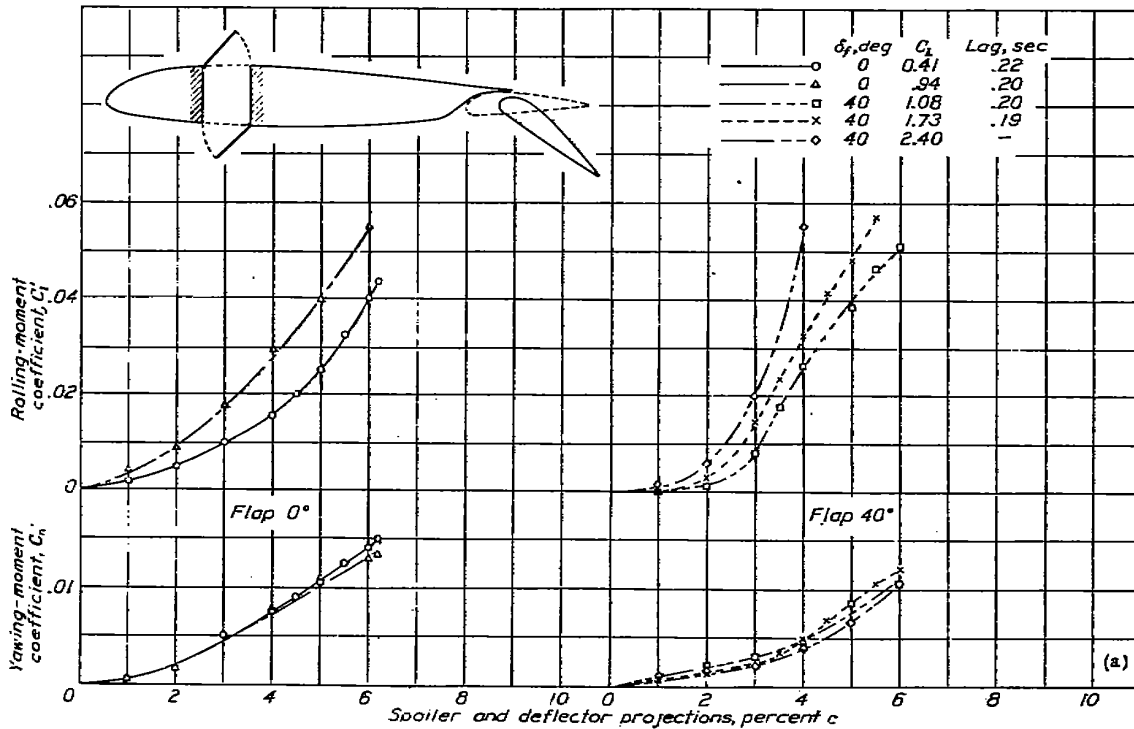

(a) Spoiler hinge at 0.20c; deflector hinge at 0.30c.

FIGURE 17.

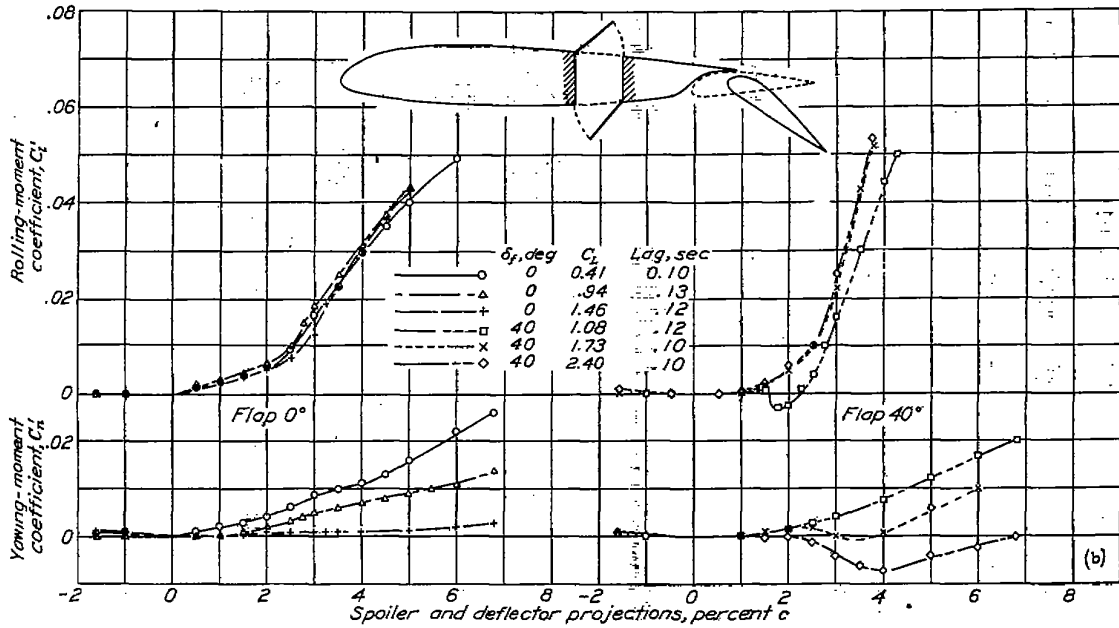

(b) Spoiler hinge at 0.50c; deflector hinge at 0.60c; projection ratio of spoiler to deflector, 1:1.

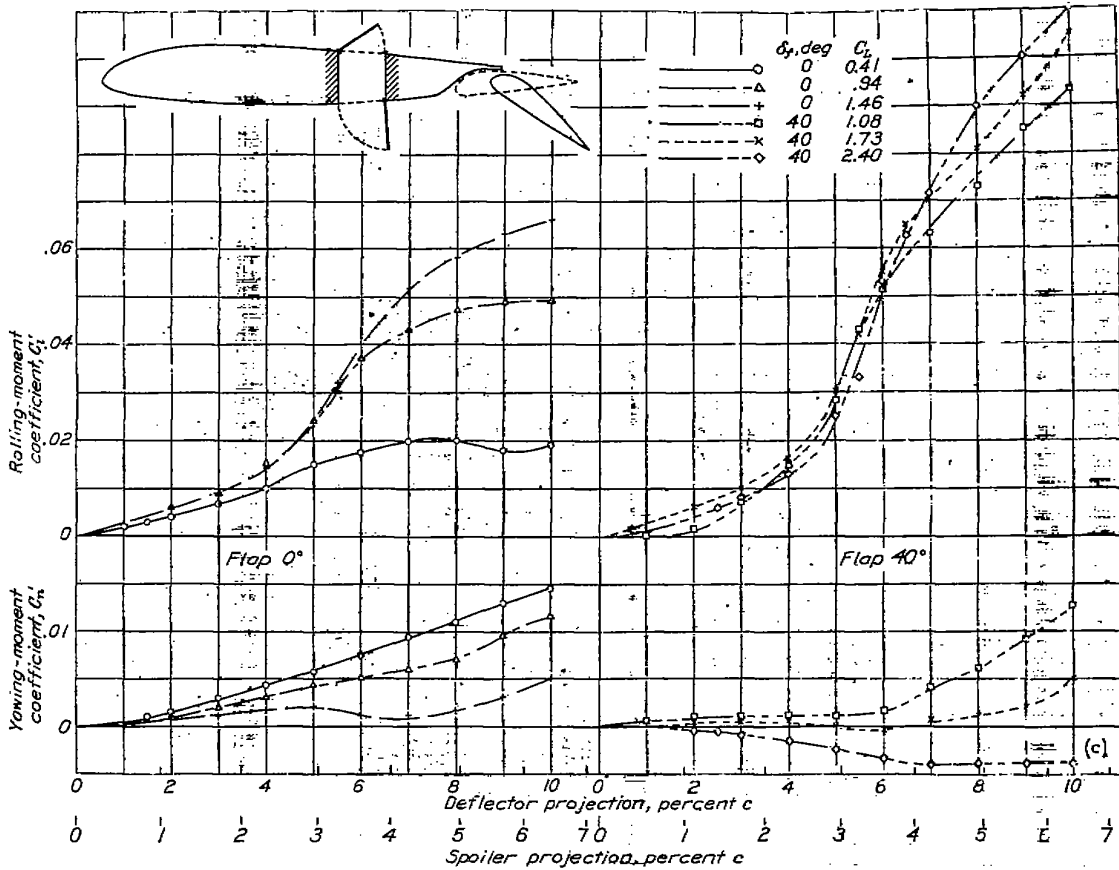

(c) Spoiler hinge at 0.50c; deflector hinge at 0.60c; projection ratio of spoiler to deflector about 2:3.

FIGURE 17.—Rolling- and yawing-moment coefficients due to a 0.10c spoiler and a 0.10c deflector with a slot on a NACA 23012 wing with a 0.250c full-span slotted flap.

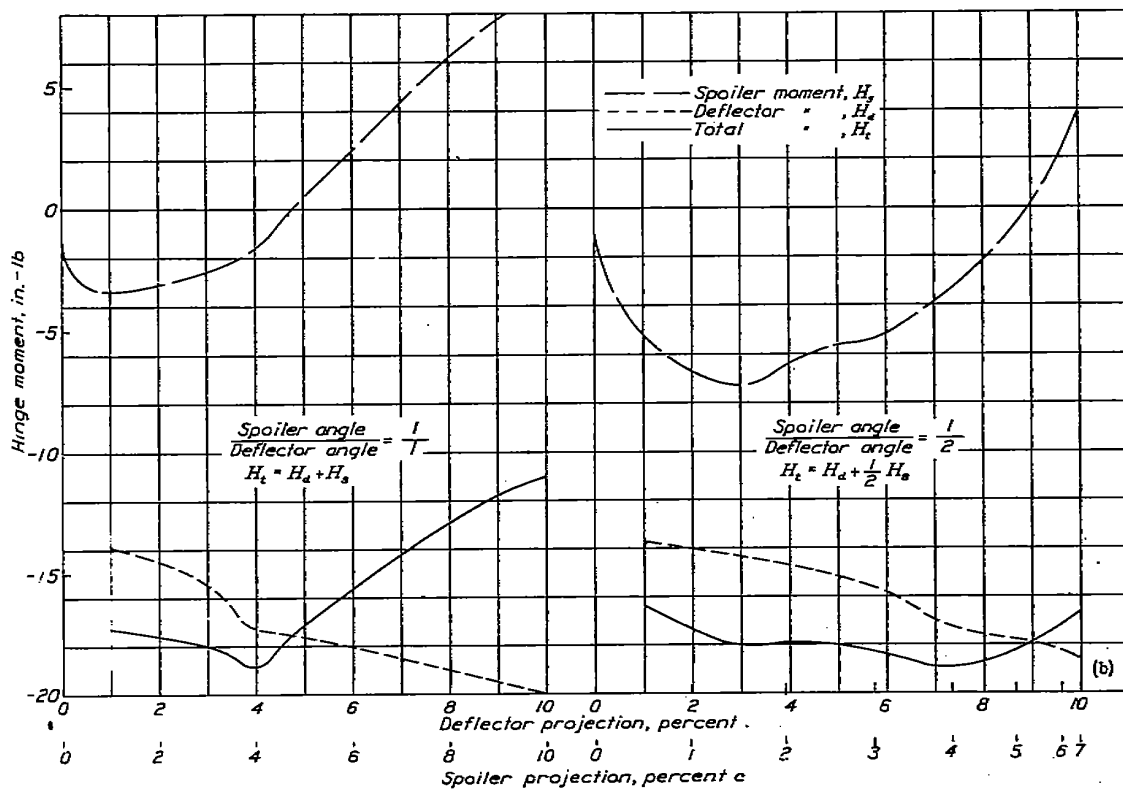
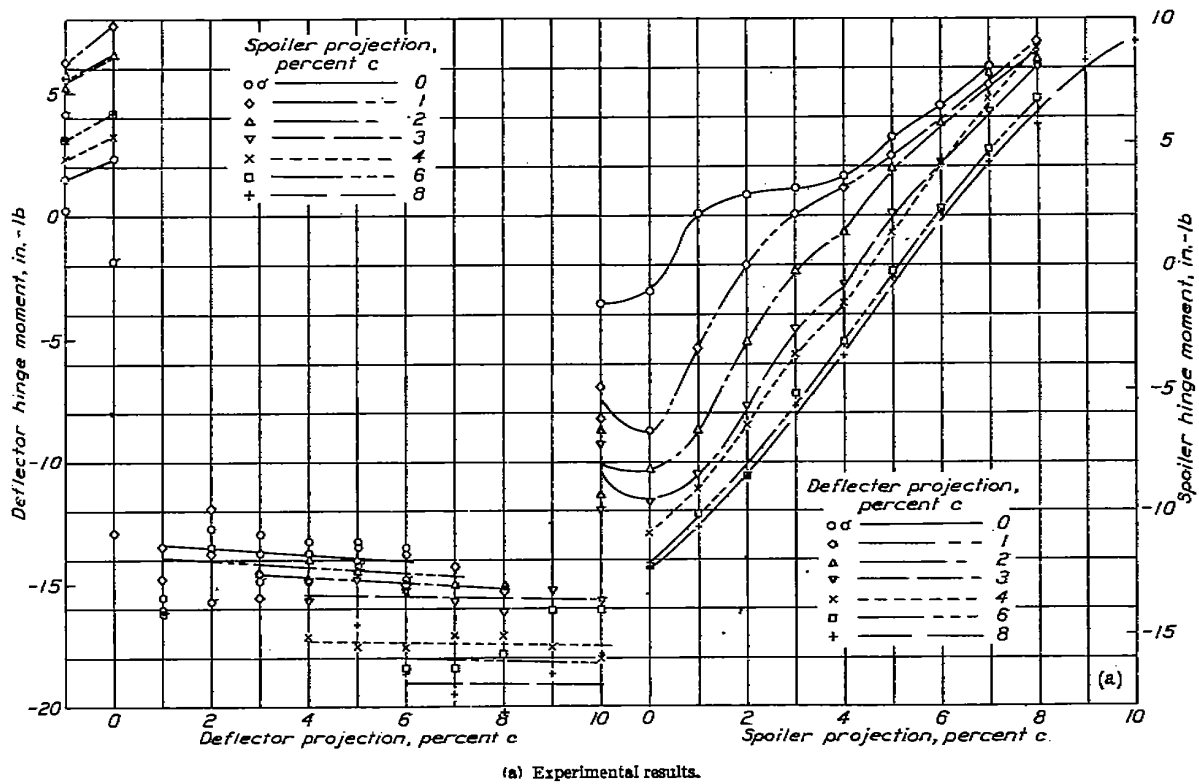

(b) Computed hinge moments for particular linkages.

FIGURE 18.—Hinge moments at 40 miles per hour of a 0.10c spoiler hinged at 0.60c and of a 0.10c deflector hinged at 0.60c with a slot on an NACA 23012 wing with a 0.2668c full-span slotted flap. Flap neutral;  $C_L$  0.41. (See fig. 17 for sketch.)

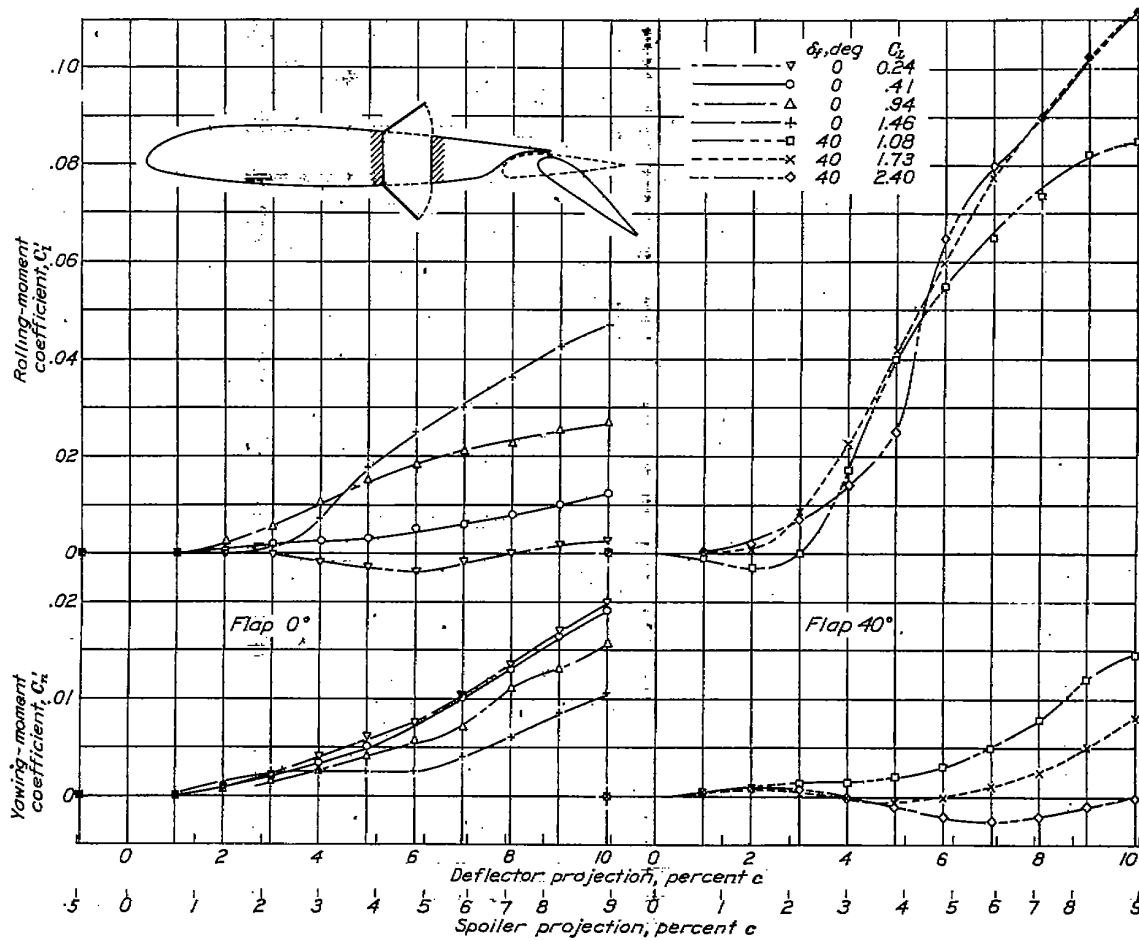
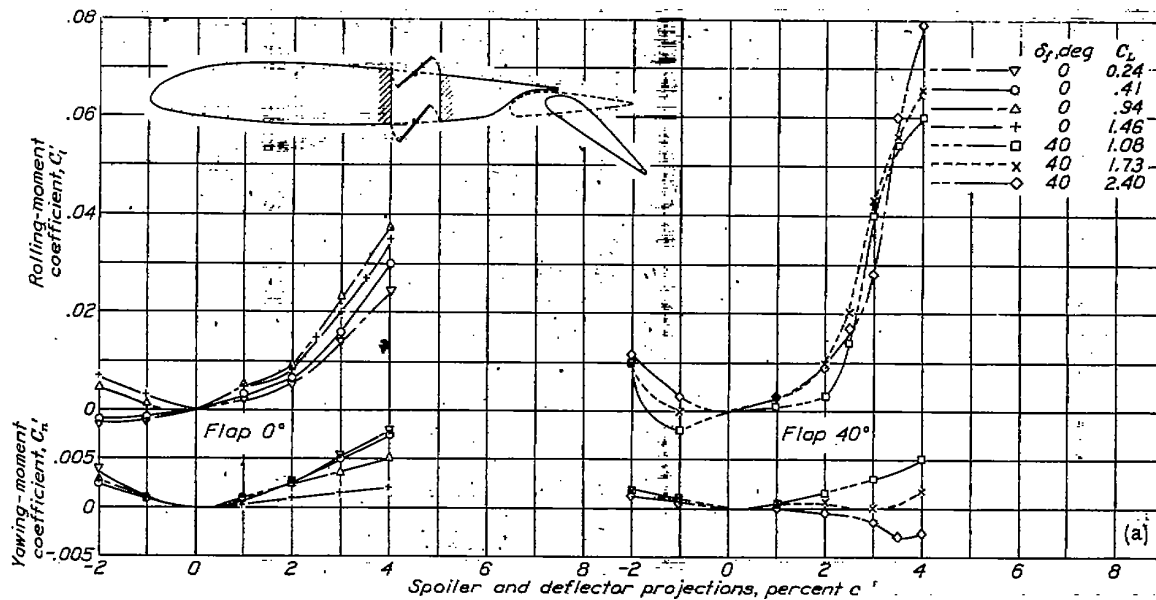
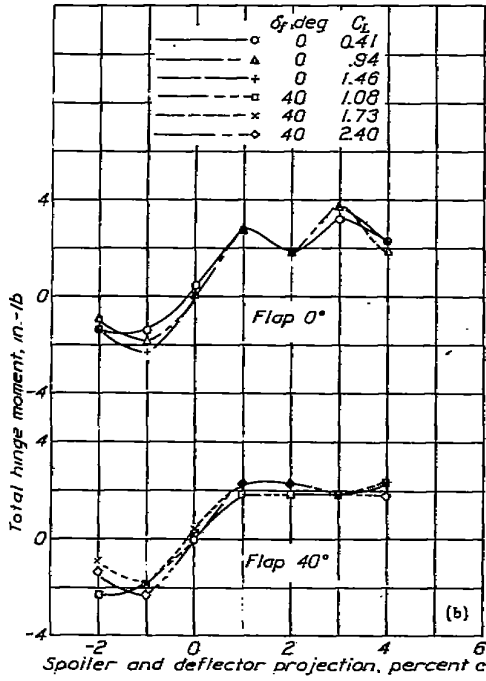

FIGURE 19.—Rolling- and yawing-moment coefficients due to a 0.10c spoiler hinged at 0.50c and a 0.10c deflector hinged at 0.50c with a slot on an NACA 23012 wing with a 0.250c full-span slotted flap.



(a) Rolling- and yawing-moment coefficients.

FIGURE 20.



(b) Hinge moment at 40 miles per hour.  
 FIGURE 20.—A 0.10c spoiler hinged at 0.55c and a 0.10c deflector hinged at 0.55c with a slot on an NACA 23012 wing with a 0.2566c full-span slotted flap.

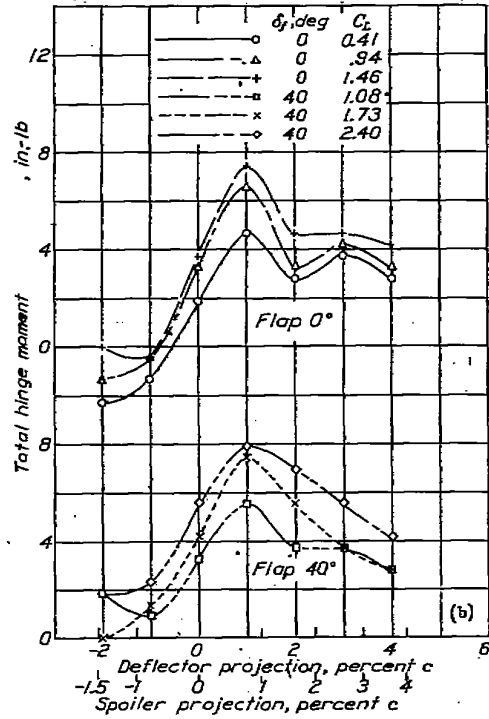

(b) Hinge moment, measured at deflector, at 40 miles per hour.  
 FIGURE 21.—A 0.10c spoiler hinged at 0.50c and a 0.10c deflector hinged at 0.55c with a slot on an NACA 23012 wing with a 0.2566c full-span slotted flap.

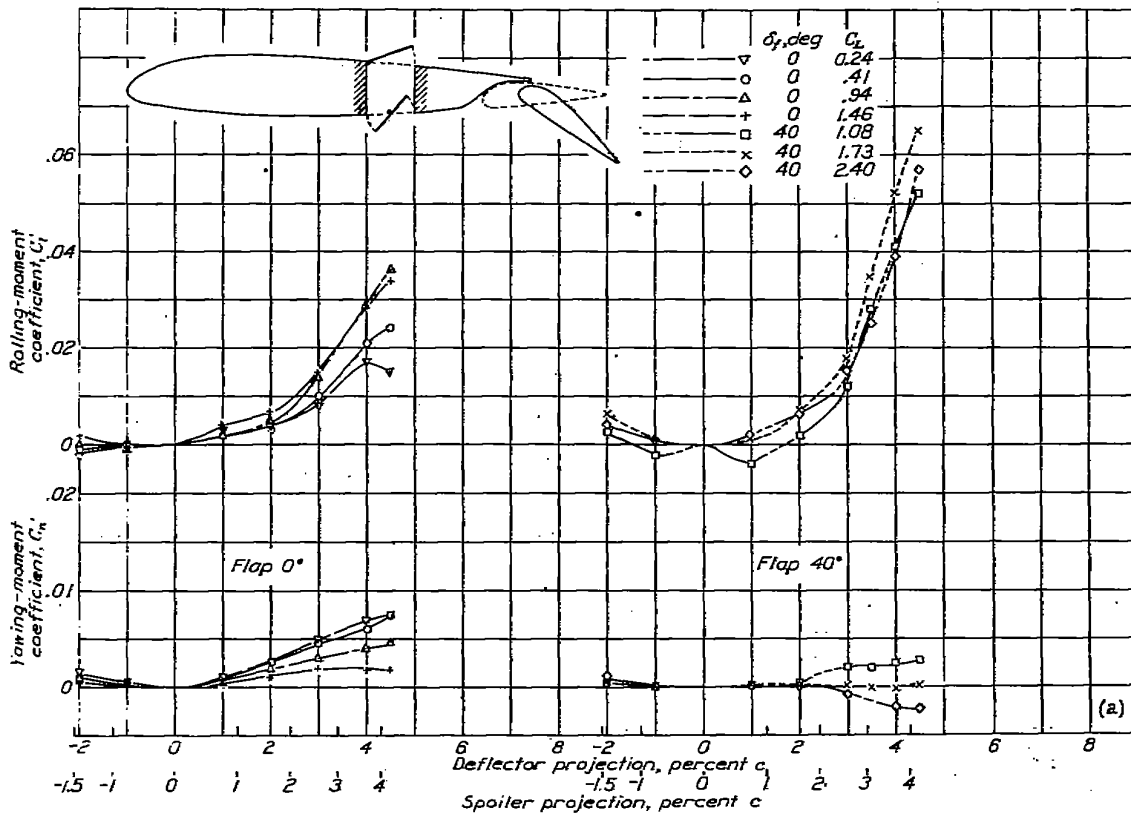

(a) Rolling- and yawing-moment coefficients.

FIGURE 21.

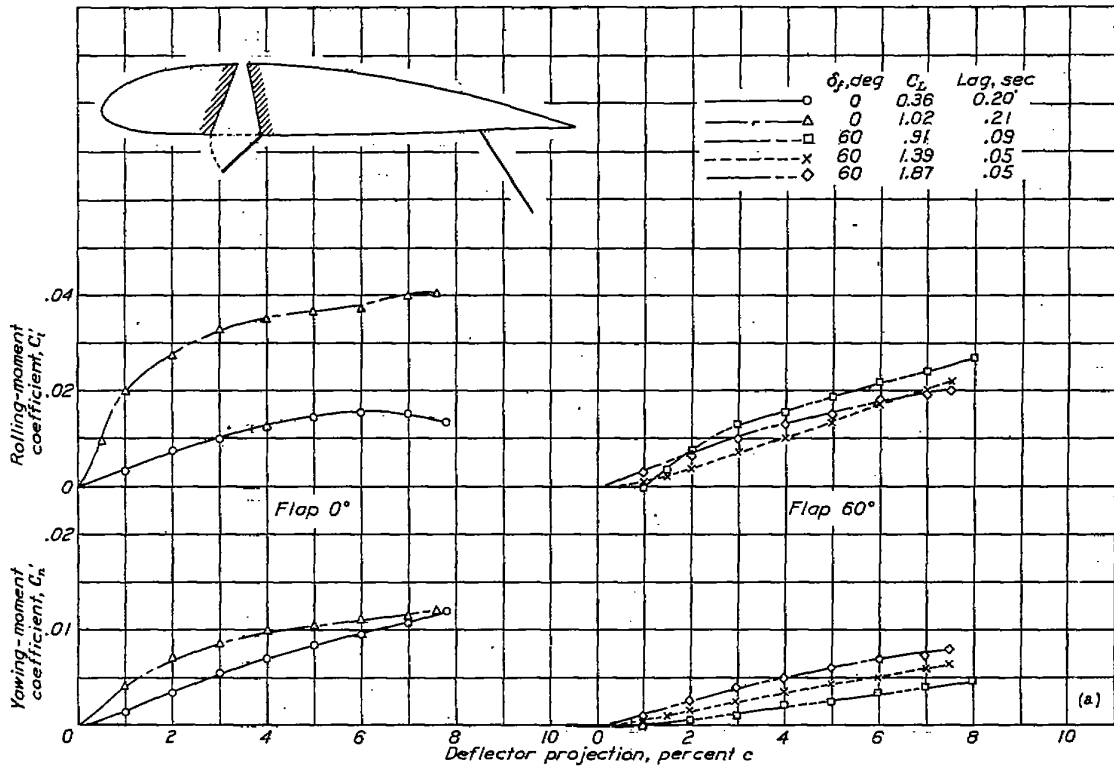

(a) Slot width at top, 0.02c.

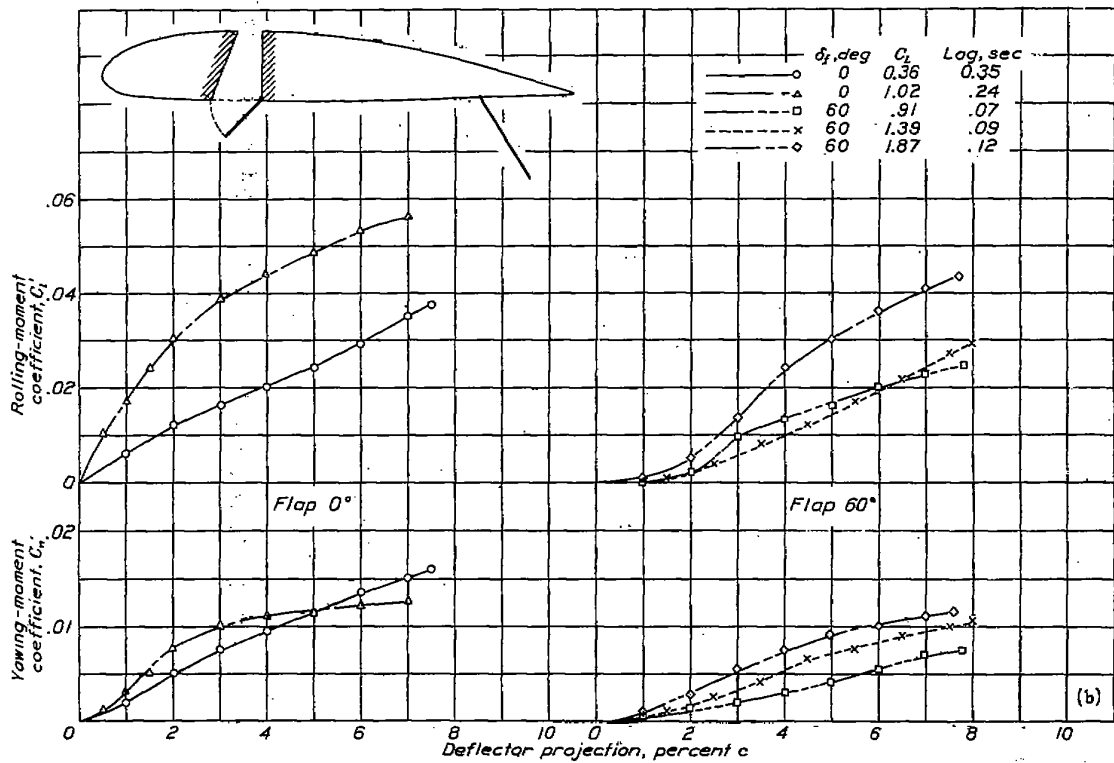

(b) Slot width at top, 0.05c.

FIGURE 22.



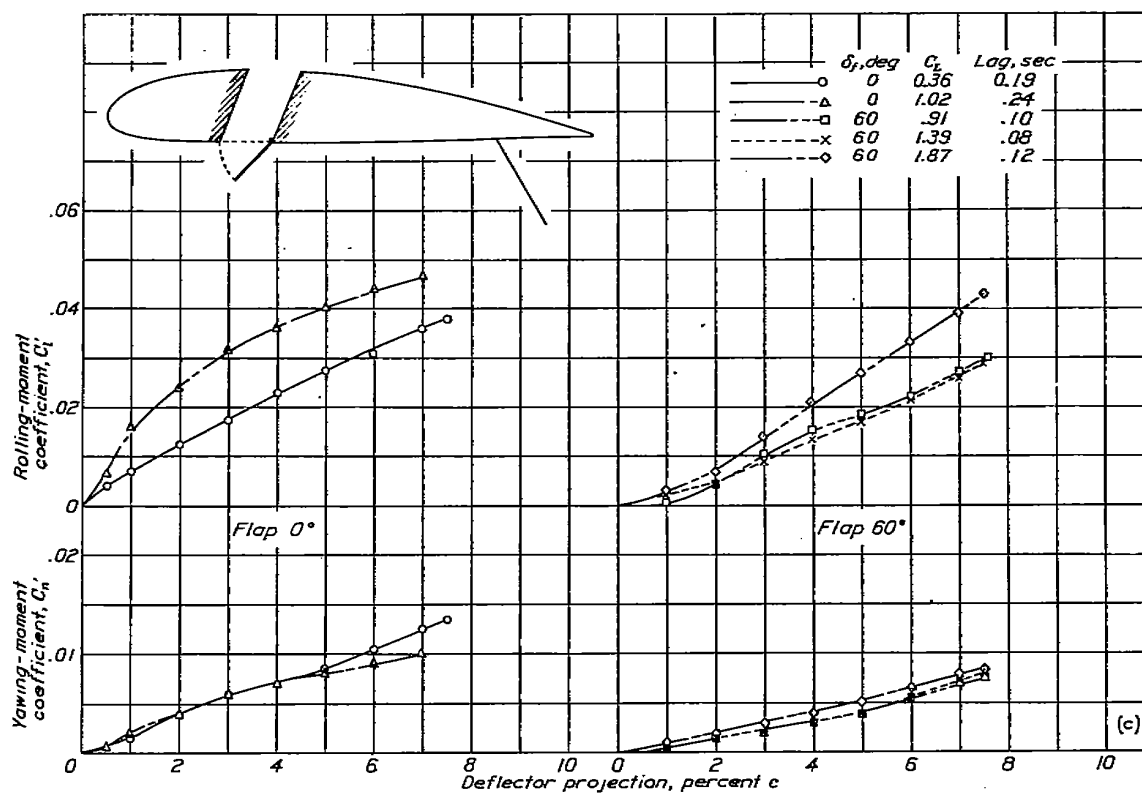

(c) Slot width at top, 0.11c.

FIGURE 22.—Rolling- and yawing-moment coefficients due to an 0.11c deflector hinged at 0.31c and a slot on a Clark Y-15 wing with a 0.20c full-span split flap

## DEFLECTORS

In figures 8 to 11 are presented the characteristics of devices that deflect the flow past the lower surface of the wing. Their effectiveness as lateral-control devices appears to be dependent upon the favorable pressure gradient of the lower surface, which tends to cause the flow to return to the wing surface behind the deflector. The action of deflectors is therefore in direct contrast to that of spoilers, which operate in the adverse pressure gradient of the wing upper surface that tends to prevent a return of the flow to the surface. Because of their contrasting aerodynamic action, spoilers and deflectors generally produce rolling moments of the same sign. Although the maximum rolling moments obtained were not large, the deflectors were more effective than spoilers at small projections.

The results show that the rolling- and the yawing-moment characteristics, particularly when the flaps were neutral, were considerably affected by the fore-and-aft location of the deflectors. The lag of these devices in all locations, however, was small relative to that of spoilers, as would be expected from their contrasting aerodynamic action.

The retractable deflector (fig. 8 (a)), which was made of a thin metal sheet, had negligible aerodynamic hinge moments. The hinge moments of one of the rearwardly hinged flap-type deflectors are shown in figure 9 (c) and those of the forwardly hinged deflector are shown in figure 10 (b). The hinge moments shown in figure 10 (b) might be acceptable; those shown in figure 9 (c) probably would not.

The slot-closing deflector (fig. 11) might well be in a class by itself. Its action is dependent upon the reduction of lift caused by partly closing the high-lift slot in front of the flap. In general, the rolling moment or the lift reduction was greater with about 1 percent of the slot remaining open than with the slot completely closed, as was expected from previous tests of flaps with and without leakage gaps. A slot-closing deflector (which could be of the sliding-plate, the flap, or the retractable type) offers promise as a means of covering the slot when the flap is neutral and of augmenting the lateral control when the flap is deflected.

## SPOILER-DEFLECTOR COMBINATIONS

The characteristics of spoiler-deflector combinations are shown in figures 12 to 14. The rolling- and the yawing-moment characteristics of any given combination are roughly a summation of the characteristics of its components; the lag is roughly a weighted average. As would be expected, the characteristics of the combination were, in general, improved by rearward movement of the location of the spoiler. Of the combinations tested the most promising appeared to be the retractable aileron and a forwardly hinged deflector linked together for equal projection, as shown in figure 14 (b). The hinge moments for the deflector in this combination were practically the same as those given in figure 10 (b) for the deflector alone, that is, the presence of the retractable aileron did not greatly affect the hinge moments of the deflector.

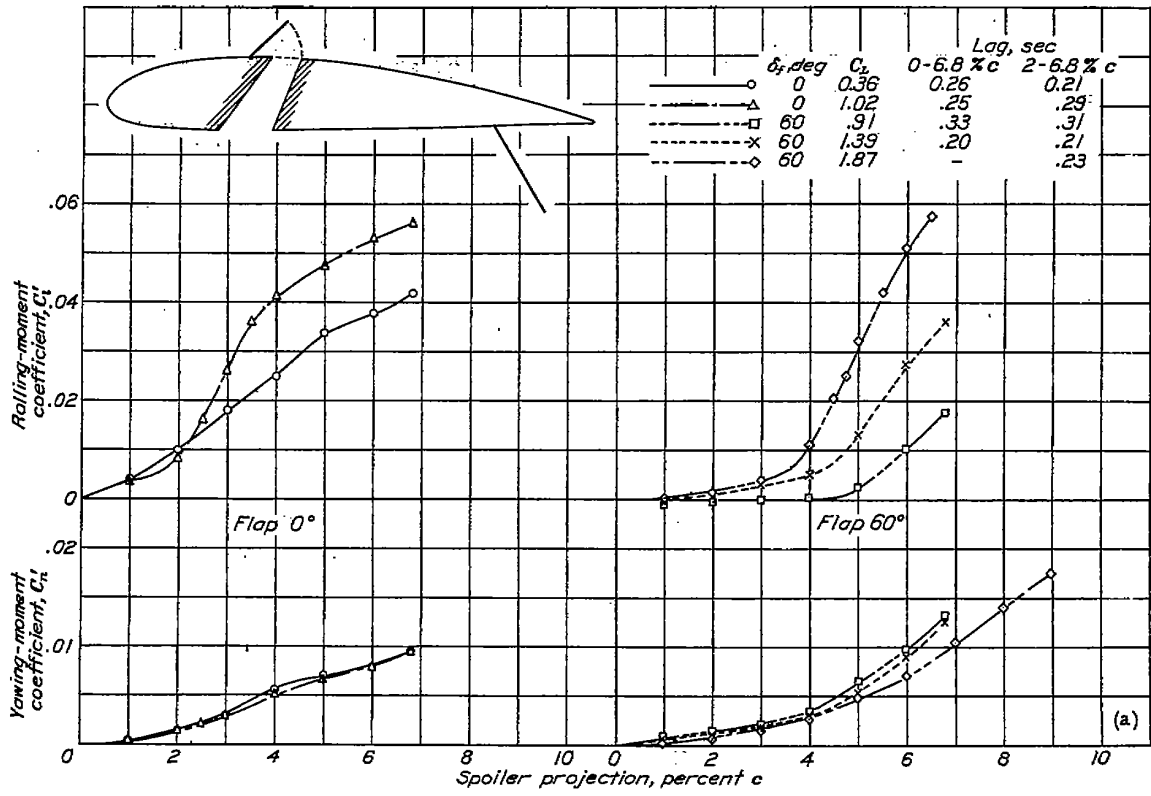

(a) Spoiler hinge at 0.20c.

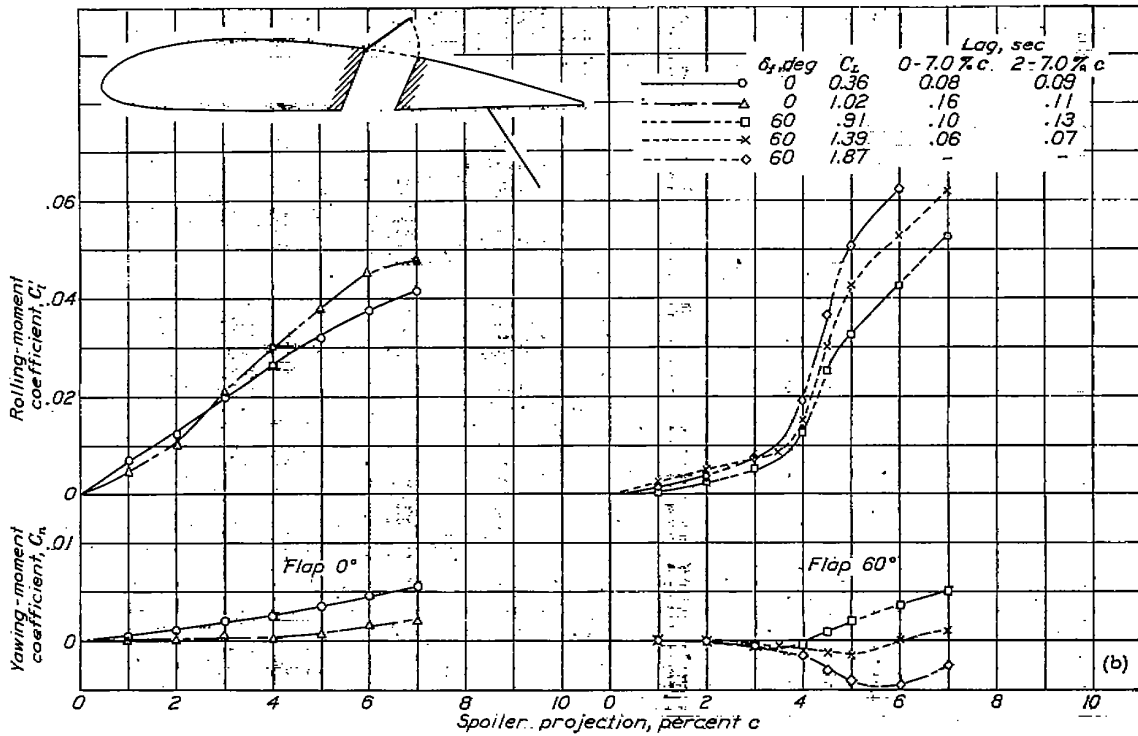

(b) Spoiler hinge at 0.55c.

FIGURE 23.—Rolling- and yawing-moment coefficients due to an 0.11c spoiler and a slot on a Clark Y-15 wing with a 0.20c full-span split flap.

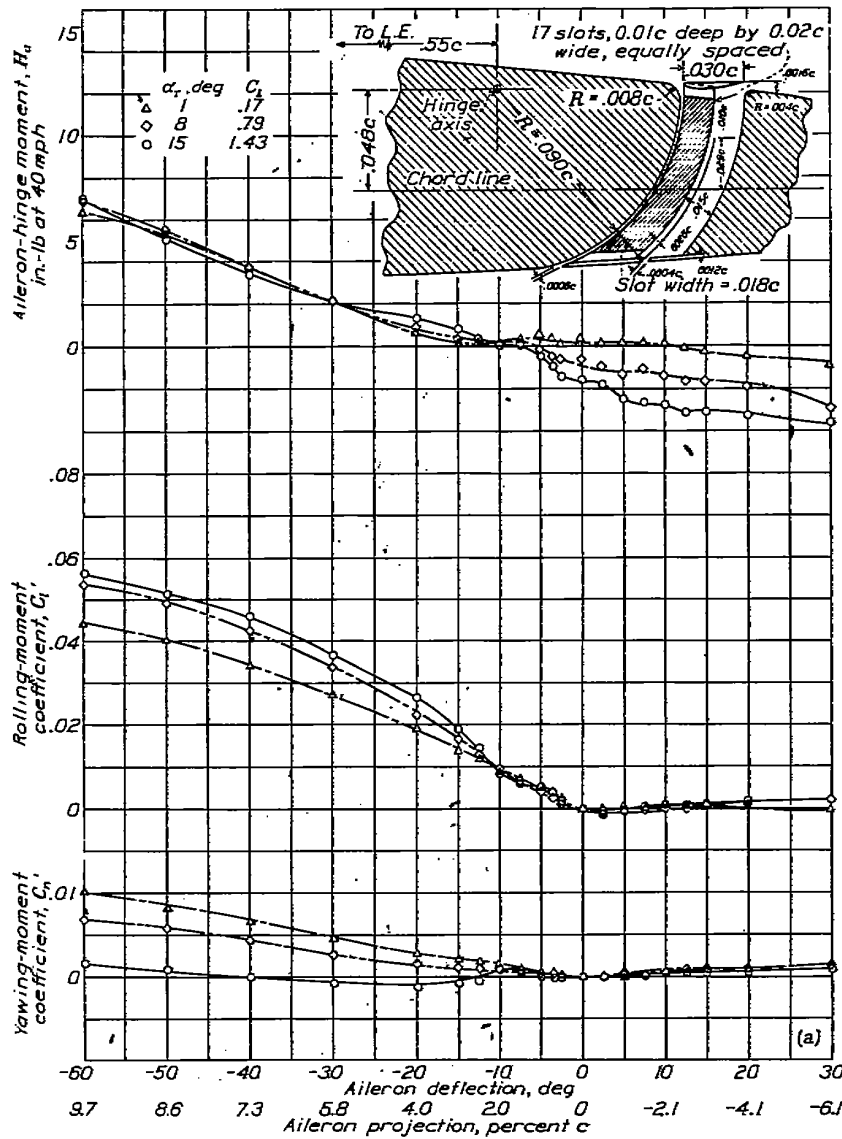

(a) Flap neutral.  
FIGURE 24.

The spoiler-deflector combination suggests a use other than for lateral control. If two combinations, one on each wing tip, were simultaneously deflected, a control for limiting the speed in dives would be obtained. One installation could thus be made to serve the two purposes of lateral control and of dive control. A somewhat similar arrangement has been used on gliders for dive control only (reference 7).

SPOILER-DEFLECTOR-SLOT COMBINATIONS

The characteristics of spoiler-deflector-slot combinations are shown in figures 15 to 21. In general, the addition of the slot improved the rolling-moment and the lag characteristics of the spoiler-deflector combination. These combinations, moreover, did not require permanent large openings in either surface of the wing,

as did combinations of a slot with either a spoiler or a deflector.

The hinge-moment characteristics of the combinations tested were not considered acceptable. General hinge-moment data, a sample of which is shown in figure 18 (a), were obtained at several angles of attack of the wing and at three flap deflections. Total hinge moments for two particular linkages of the spoiler and the deflector, computed from figure 18 (a), are shown in figure 18 (b).

Two arrangements, the characteristics of which are shown in figures 20 and 21, were investigated in an effort to improve by a simple method the hinge-moment characteristics in comparison with those previously discussed. Although some improvement resulted, neither of these arrangements was considered to be entirely satisfactory.

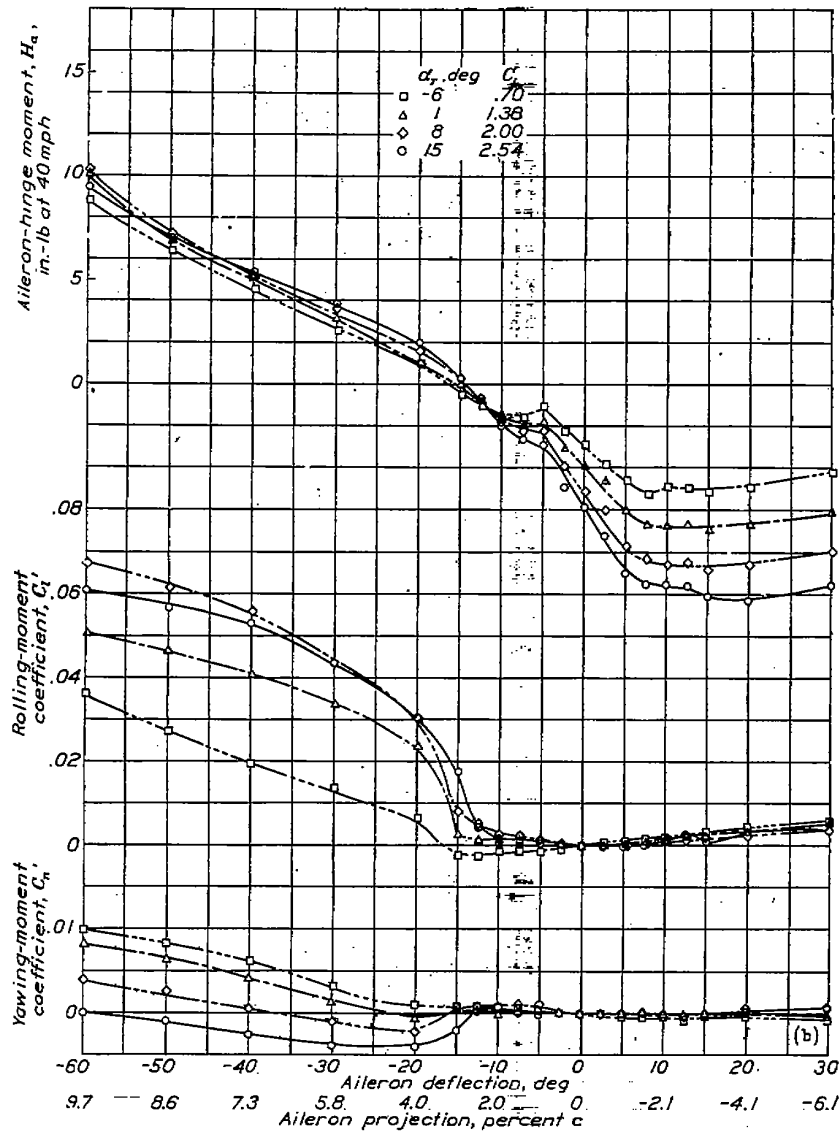

(b) The 0.20c split flap deflected 60°.

FIGURE 24.

**DEFLECTOR-SLOT COMBINATIONS**

The characteristics of a deflector in combination with three different slots are shown in figure 22. A comparison of these results with the results given in figure 8 (b) for a deflector without a slot shows that the action of the slot is similar to the action of a spoiler at the same location; that is, the jet of air ejected through the wing upper surface tends to spoil the flow over the surface behind the opening.

**SPOILER-SLOT COMBINATIONS**

**Flap type.**—The characteristics of flap-type spoiler-slot combinations installed on the Clark Y-15 wing with the split flap are shown in figure 23. A rearward movement of the location of the device was found beneficial. Comparison of these results with the results given in figure 4 for a spoiler without a slot shows that

the slot improved both the rolling-moment and the lag characteristics. A device that requires a large permanent opening in the surface of the wing is not, in general, acceptable because of its detrimental effect upon the performance of the airplane. (See reference 4.) This combination was not tested on the wing with slotted flaps.

**Plug type.**—The characteristics of a plug-type spoiler-slot aileron are presented in figure 24. This device is closely related to those discussed in the preceding sections of this report and has been recently developed as an extension of the present investigation. The device appears to be satisfactory as regards rolling, yawing, and hinge moments on the plain wing (fig. 24 (a)) but is ineffective in producing rolling moments at projections below 3 percent chord on the wing with split flap deflected 60° (fig. 24 (b)); this characteristic might be

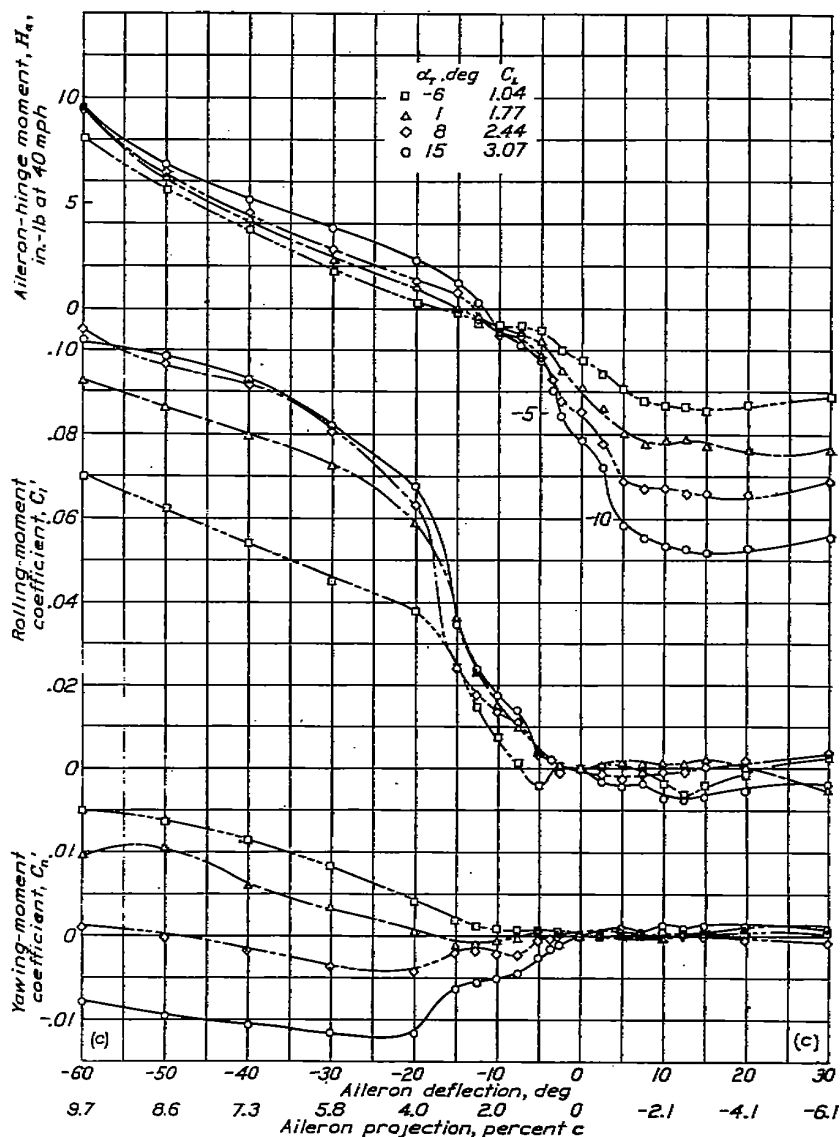

(c) The 0.2586c slotted flap deflected 40°.

FIGURE 24.—Rolling-, yawing-, and hinge-moment characteristics due to a plug-type spoiler-slot aileron on an N.A.C.A. 23012 wing with a full-span flap.

improved by a rearward movement of the location of the device. On the wing with the slotted flap deflected 40° (fig. 24 (c)) all the rolling-, the yawing-, and the hinge-moment characteristics appear to be acceptable, as was also found to be true at flap deflections of 0°, 20°, and 30°. The lateral-control characteristics of this device make it one of the most promising lateral-control devices investigated for use on wings with full-span slotted flaps.

#### TIME HISTORIES

The numerical lag values are suitable for a rough comparison of various devices but do not convey all of the time-response information thought to be of interest. Some of the effects noted will be briefly described. Spoilers near the leading edge of a wing had previously been found to give a momentary increase in lift before

the decrease to the final value (reference 4). This tendency was also noted in the present tests. In addition, some deflectors that gave a final increase in lift were observed to give first a decrease. In a combination of spoilers with such deflectors, the reverse effects would tend to counteract each other.

Most of the devices caused a small oscillation of the wing (see fig. 2) when the device was held in a deflected position. These oscillations did not die out but were maintained as long as the control was held in the same position, indicating that the flow over the wing behind the device was unsteady. Verification of the existence of such a condition was obtained with tufts. Similar effects have been noted in the use of some spoilers as air brakes on gliders (reference 7). In the case of the glider, the difficulty was overcome by leaving a gap between the wing surface and the spoiler.

The variable nature of the flow would be expected to cause some variation in the time-response characteristics. Such variations were noted in repeat tests and may have been responsible in part for the erratic variation in lag of a given device with initial lift conditions.

Almost all of the devices were observed to give a more rapid response when moved to neutral than when moved from neutral. If the initial flow conditions, device neutral, were such that the tip was on the verge of stalling, however, the reverse might be expected to be true.

Final yawing moments for most of the devices were found to be positive although, for the high-lift condition, some had negative moments. These devices, however, gave an initial positive yawing moment, generally of considerable size, simultaneously with the operation of the device and then a gradual change to the final value when that value differed from the initial one. This phenomenon was very noticeable during tests of the retractable aileron and was thought to be due to the sudden deceleration of the air during operation of the device.

#### CONCLUDING REMARKS

1. Spoilers alone were found to be generally unsuitable for lateral control on wings with full-span split or slotted flaps because of excessive lag and because of ineffectiveness at small spoiler projections. The characteristics were improved as the location of the device was moved toward the trailing edge of the wing. Spoilers alone may give acceptable control for some types of airplane if they are located sufficiently near the wing trailing edge.

2. Deflectors alone were not so effective as spoilers at large projections but were generally more effective at small projections and had less lag than spoilers alone. The combination of a deflector and a spoiler was more effective at small projections and had less lag than the spoiler alone. The most satisfactory combination tested was that of a forwardly hinged deflector and a retractable aileron with equal projections.

3. A slot-closing deflector for use on wings with slotted flaps offers promise as a means of decreasing wing drag when the slotted flap is neutral and of augmenting the lateral control when the flap is deflected.

4. The addition of a slot to the combination of a spoiler and a deflector offered further improvement of the static-moment and the lag characteristics. This combination appears promising, although the hinge-moment characteristics of the arrangements tested were not satisfactory. The hinge-moment characteristics could probably be made satisfactory by further development.

5. A plug-type spoiler-slot aileron appeared to be the most satisfactory lateral-control device investigated for use on a wing with a full-span slotted flap. Flight tests of this arrangement are recommended.

LANGLEY MEMORIAL AERONAUTICAL LABORATORY,  
NATIONAL ADVISORY COMMITTEE FOR AERONAUTICS,  
LANGLEY FIELD, VA., August 13, 1940.

#### REFERENCES

1. Weick, Fred E., and Jones, Robert T.: *Résumé and Analysis of N.A.C.A. Lateral Control Research*. Rep. No. 605, NACA, 1937.
2. Weick, Fred E., and Shortal, Joseph A.: *Wind-Tunnel Research Comparing Lateral Control Devices, Particularly at High Angles of Attack. V—Spoilers and Ailerons on Rectangular Wings*. Rep. No. 439, NACA, 1932.
3. Weick, Fred E., Soulé, Hartley A., and Gough, Melvin N.: *A Flight Investigation of the Lateral Control Characteristics of Short Wide Ailerons and Various Spoilers with Different Amounts of Wing Dihedral*. Rep. No. 404, NACA, 1934.
4. Shortal, Joseph A.: *Wind-Tunnel and Flight Tests of Slot-Lip Ailerons*. Rep. No. 602, NACA, 1937.
5. Irving, H. B., and Batson, A. S.: *Some Early Model Experiments on Devices for Improving Lateral Control near the Stall*. R. & M. No. 1251, British A. R. C., 1929.
6. Wenzinger, Carl J., and Harris, Thomas A.: *Wind-Tunnel Investigation of an NACA 23012 Airfoil with Various Arrangements of Slotted Flaps*. Rep. No. 664, NACA, 1939.
7. Jacobs, Hans, and Wanner, Adolf: *DFS Dive-Control Brakes for Gliders and Airplanes*. T. M. No. 926, NACA, 1940.