

## REPORT No. 423

### WIND-TUNNEL RESEARCH COMPARING LATERAL CONTROL DEVICES, PARTICULARLY AT HIGH ANGLES OF ATTACK

#### III—ORDINARY AILERONS RIGGED UP 10° WHEN NEUTRAL

By FRED E. WEICK and CARL J. WENZINGER

##### SUMMARY

*Wind-tunnel tests have been made on three model wings having different sizes of ordinary ailerons rigged up 10° when neutral, the same models having previously been tested with the ailerons rigged even with the wings in the usual manner. One of the wings had ailerons of medium size, 25 per cent of the wing chord by 40 per cent of the semispan, one had long, narrow ailerons, and one had short, wide ones. These tests are part of a general investigation on lateral control devices, with particular reference to the control at high angles of attack, in which all the devices are being subjected to the same series of tests in the 7 by 10 foot wind tunnel of the National Advisory Committee for Aeronautics. Force tests of the usual type, free-autorotation tests, and forced-rotation tests were made showing the effect of the ailerons on the general performance of the wing, on the lateral controllability, and on the lateral stability.*

*With the ailerons rigged up 10° when neutral, negligibly small yawing moments (body axes), at all angles of attack which can be maintained by conventional airplanes, were given by the medium-sized ailerons with equal up-and-down deflection. Large favorable yawing moments, and no adverse ones with any portion of the total deflection, were given at all angles of attack by each of the three sizes of ailerons with up-only movement, by the short, wide ailerons with a medium differential movement, and by the medium-sized ailerons with an extreme differential movement. The direct rolling control was best at high angles of attack with the short, wide ailerons with an extreme differential movement, but this combination required exceptionally high control forces. For neutral setting the lateral instability was found to be less with the ailerons rigged up 10° than with them rigged even with the wing.*

##### INTRODUCTION

This report is the third of a series giving the results of an investigation in which it is hoped to compare all types of lateral control devices which have been satisfactorily used, or which show reasonable promise of being effective. It is planned first to test the various types of ailerons and lateral control devices on rectan-

gular wings of aspect ratio 6. Later the best ones are to be tested on wings of different shape. The tests show the relative merit of the various control devices in regard to lateral controllability, lateral stability, and general usefulness as shown by the lift and drag characteristics. They include regular 6-component force tests with the ailerons or other control devices both neutral and deflected various amounts, rotation tests in which the model is rotated about the wind-tunnel axis and the rolling moment measured, and free-rotation tests showing the range and rate of autorotation. Because of the large effect of yaw on both lateral stability and control, the tests are made not only at 0° yaw, but also with an angle of yaw of 20°, which represents the conditions in a fairly severe sideslip.

The previous work in this investigation is reported under references 1 and 2. The first report covered ordinary ailerons of three different sizes. One of these was of medium size obtained from an average of several conventional ailerons; the second was long and narrow; and the third was short and wide. All were proportioned to give approximately the same rolling moments at angles of attack below the stall, and with equal up-and-down deflection. The results are given also for the ailerons set in accordance with two differential movements, with upward movement only, and with the ailerons arranged to float. It was found that, with the exception of the floating ailerons, none of those tested were entirely free from adverse yawing moments. An examination of the results, however, indicated that improved aileron control with no adverse yawing moments might be obtained with ordinary ailerons if they were rigged so that both ailerons had a negative, or upward, deflection of about 10° when neutral and were given an up-only or an extreme differential movement starting from that point. In this case, it seemed that very good rolling control could be obtained at the high angles of attack just above the stall, and judging from the previous tests with the ailerons floating, the stability in roll would be improved. In addition, with upward movement only, the hinge

moments would practically all be in the same direction, which is not true with the ailerons rigged even with the wing.

The present report covers tests which have been made with the ailerons rigged up 10° when neutral.

APPARATUS AND METHODS

Wind tunnel.—All the tests were made in the 7 by 10 foot open-jet wind tunnel of the National Advisory Committee for Aeronautics. In this tunnel, the model is supported in such a manner that the forces and moments at the quarter-chord point of the mid section of the model are measured directly in coefficient form.

semispan, the long, narrow ones are 15 per cent of the chord by 60 per cent of the semispan, and the short, wide ones are 40 per cent of the chord by 30 per cent of the semispan.

Angle at which ailerons should be rigged when neutral.—In Figure 2 are given the yawing-moment coefficients (body axes) due to the ailerons of all three sizes when individually deflected. (These results were obtained from Part I.) Considering only the upward deflection, it will be noted that the yawing-moment coefficients reach maximum adverse (negative) values at about 10° for the angles of attack of 20° and below. It is therefore apparent that if both ailerons were

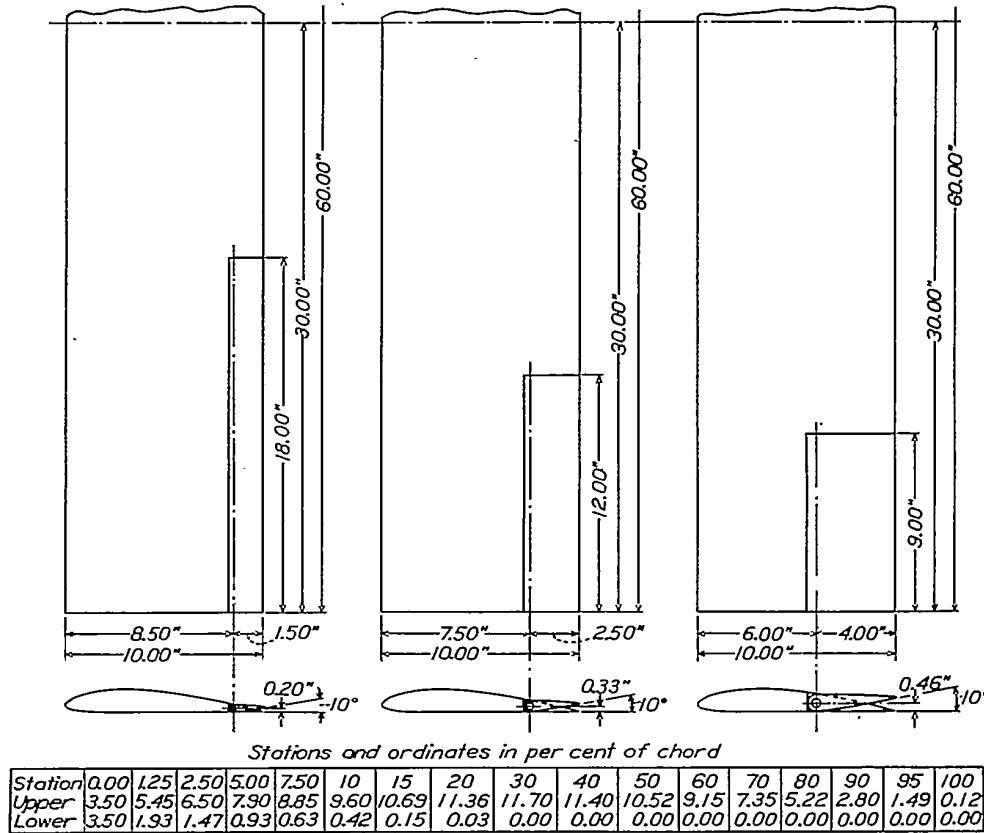

FIGURE 1.—Details of ailerons on Clark Y wings. (Neutral position 10° up)

For autorotation tests, the standard force-test tripod is replaced by a special mounting that permits the wing to rotate about the longitudinal wind axis passing through the midspan quarter-chord point. This apparatus is mounted on the balance, and the rolling-moment coefficient may be read directly during the forced-rotation tests. A more complete description of all the above equipment is given in reference 3.

Models.—The same three models were used in these tests as in the original tests of Part I. (Reference 1.) They were made of laminated mahogany, each having a 10-inch chord and 60-inch span. The sizes of the ailerons are as shown in Figure 1. The medium ones are 25 per cent of the wing chord by 40 per cent of the

deflected upward 10° when neutral, the adverse yawing moments should be practically eliminated over the full range of angles of attack and aileron deflection by using upward movement only. Also, since the variation of yawing moment is greater for upward travel than for downward travel, by starting with 10° it seemed likely that the adverse yawing moments could be practically eliminated with the proper differential movement. The results in Figure 2 have been replotted in Figure 3 on the basis of the ailerons neutral with 10° upward deflection. Figure 3 shows that the adverse yawing moments are practically eliminated at all angles of attack for the upward aileron movement. From this point of view, the upward deflection of 10°

when neutral is apparently about as satisfactory a value as can be obtained for all three aileron sizes. The favorable yawing moments with upward deflection are in most cases as great as, or greater than, the adverse yawing moments with downward deflection, from which it would seem that within reasonable limits any desired amount of yawing moment can be obtained by the use of a suitable differential movement.

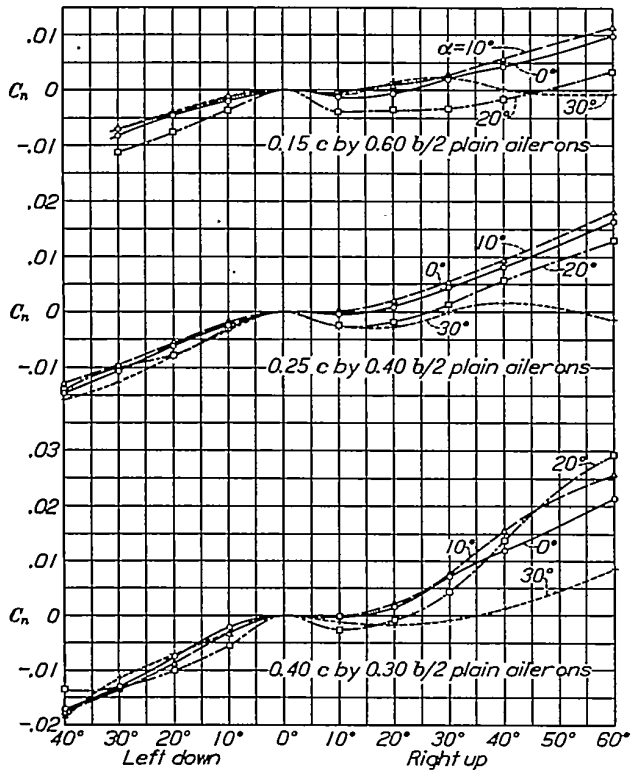

FIGURE 2.—Yawing-moment coefficient due to ailerons deflected individually (body axes). Ailerons neutral 0° to wing chord

**Aileron movements.**—Three types of aileron deflection were used in these tests: Equal up-and-down, upward movement only, and downward movement only. From these settings data were obtained directly for the equal up-and-down and the up-only movements. For differential arrangements the rolling and yawing moments were taken as the sum of the moments obtained separately on the up-only and down-only tests. This assumption is not rigorously correct, owing to the difference in the effect of the ailerons on the span load distribution over the wing when they are deflected separately or together. However, check tests comparing the moments as obtained by either simultaneous or separate deflection show that the error due to this method of computation is small for the cases under discussion. Results have been computed for the same four series of deflections that were given in Part I. For the first of these, equal up-and-down, a maximum deflection of  $\pm 25^\circ$  is assumed; the next is an average differential movement with a maximum upward displacement of  $35^\circ$  and a

downward displacement of  $15^\circ$ ; the third is an extreme differential movement of which the maximum values are  $50^\circ$  up and  $7^\circ$  down, and the last is upward movement only with a maximum deflection of  $60^\circ$ . The various relative displacements with the two differential movements are given in Table I, and linkage arrangements which were assumed for control-force computations are given in Figure 4 for all of the movements.

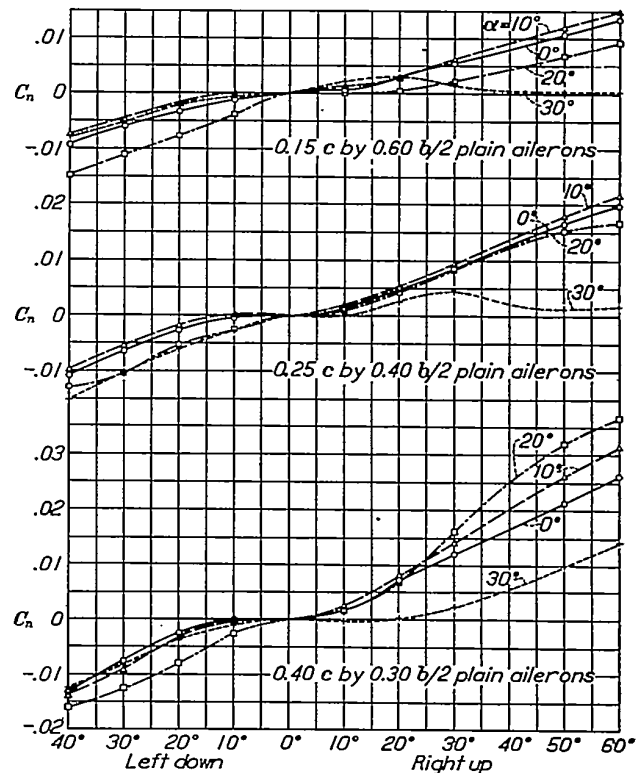

FIGURE 3.—Yawing-moment coefficient due to ailerons deflected individually (body axes). Ailerons neutral up  $10^\circ$  from wing chord

TABLE I  
ASSUMED DIFFERENTIAL AILERON ARRANGEMENTS

[Ailerons neutral at  $10^\circ$  up from wing chord]

Average differential (No. 1)			Extreme differential (No. 2)		
Drive crank angle from $39^\circ$	Aileron deflection <sup>b</sup>		Drive crank angle from $46^\circ$	Aileron deflection <sup>c</sup>	
	Up	Down		Up	Down
0°	0.0°	0.0°	0°	0.0°	0.0°
10°	8.6°	7.0°	10°	7.5°	5.5°
20°	17.0°	12.0°	20°	14.0°	10.4°
30°	28.0°	14.8°	30°	24.8°	13.6°
40°	40.0°	15.2°	40°	35.5°	13.1°
50°	60.0°	13.5°	50°	55.7°	3.3°

<sup>a</sup> Drive crank initial angle from vertical. (See Fig. 4.)  
<sup>b</sup> Aileron crank angle  $80^\circ$  to aileron chord.  
<sup>c</sup> Aileron crank angle  $55^\circ$  to aileron chord.

The values of the rolling and yawing moment coefficients with the ailerons deflected various amounts were taken from the results of Part I of this investigation and recomputed for the condition with the ailerons up  $10^\circ$  when neutral. New tests were required,

however, in order to find the effect on the general performance of the wing and on the lateral stability for the neutral condition with the ailerons both set  $10^\circ$  up.

**New tests.**—These tests were conducted in accordance with the standard procedure, and at the dynamic pressure and Reynolds Number employed throughout the entire series of investigations on lateral control. (Reference 1.) The dynamic pressure was 16.39 pounds per square foot, corresponding to a speed of

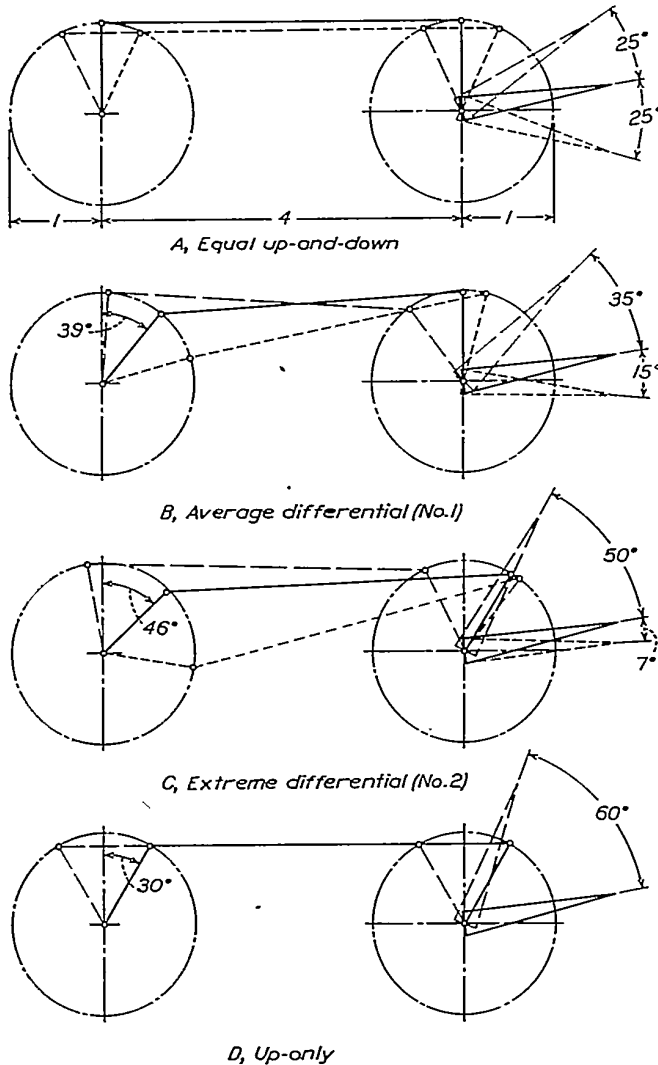

FIGURE 4.—Aileron linkage systems. Assumed maximum deflection with the neutral  $10^\circ$  up

80 miles per hour in standard air, and the Reynolds Number was 609,000.

The regular force tests were made at a sufficient number of angles of attack to determine the maximum lift coefficient, the minimum drag coefficient, and the drag coefficient at  $C_L=0.70$ . Free-autorotation tests were made in which the value  $\frac{p'b}{2V}$  was obtained for each wing throughout the entire angle-of-attack range. Forced-rotation tests were also made in which the

rolling moment while rolling was measured at the rotational velocity corresponding to  $\frac{p'b}{2V}=0.05$ , and at angles of yaw of both  $0^\circ$  and  $-20^\circ$ .

**Accuracy.**—The accuracy of the results in this report is the same as that in Part I. (Reference 1.) It is considered satisfactory at all angles of attack except in the burbled region between  $20^\circ$  and  $25^\circ$ , where the rolling and yawing moments are relatively unreliable owing to the critical and often unsymmetrical condition of the air flow around the wing.

## RESULTS

**Coefficients.**—The force-test results are given in the form of absolute coefficients of lift and drag and of the rolling and yawing moments:

$$C_L = \frac{\text{Lift}}{qS}$$

$$C_D = \frac{\text{Drag}}{qS}$$

$$C_l' = \frac{\text{Rolling moment}}{qbS}$$

$$C_n' = \frac{\text{Yawing moment}}{qbS}$$

where  $S$  is the total wing area,  $b$  is the wing span, and  $q$  is the dynamic pressure. The coefficients as given above are obtained directly from the balance and refer to the wind (or tunnel) axes. In special cases in the discussion where the moments are used with reference to body axes, the coefficients are not primed. Thus the symbols for the rolling and yawing moment coefficients about body axes are  $C_l$  and  $C_n$ .

The results of the forced-rotation tests are given, also about the wind axes, by a coefficient representing the rolling moment due to rolling:

$$C_\lambda = \frac{\lambda}{qbS}$$

where  $\lambda$  is the rolling moment measured while the wing is rolling, and the other factors have the usual significance.

This coefficient may be used as a measure of the degree of lateral stability or instability of a wing under various rolling conditions. In the present case, it is used to indicate the characteristics of a wing when it is subjected to a rolling velocity equal to the maximum likely to be encountered in controlled flight in very gusty air. This rolling velocity may be expressed in terms of the wing span as

$$\frac{p'b}{2V}=0.05$$

where  $V$  is the air speed at the center section of the wing.

Tables.—The results of these tests are given in Tables II to VII, inclusive. Table II contains the lift and drag coefficients at various angles of attack for the wing with long, narrow ailerons, and Table III gives the results of the rotation tests of the same wing. Tables IV and V give the results of the force and rotation tests, respectively, for the wing with medium-sized ailerons, and Tables VI and VII for the wing with short, wide ailerons.

#### DISCUSSION IN TERMS OF CRITERIONS

A series of criterions was developed in Part I for the purpose of comparing the effect of various ailerons or other lateral control devices on the general performance of an airplane, on its lateral controllability, and on its lateral stability. The present ailerons with their various movements are compared with each other by means of these criterions in Table VIII. In addition, the original values for the ailerons rigged even with the wing when neutral are given in Table IX for comparison.

##### GENERAL PERFORMANCE

Wing area required for desired landing speed.—The value of the maximum lift coefficient was used as a criterion of the wing area required for the desired landing speed, or conversely for the landing speed obtained with a given wing area. All three wings with both ailerons rigged up 10° gave maximum lift coefficients about 6 per cent lower than with the ailerons rigged even with the wings.

Speed range.—The ratio  $C_{Lmax}/C_{Dmin}$  is a convenient figure of merit for comparison of the relative speed range obtained with various wings. Rigging both ailerons up 10° reduced the speed range 6 per cent for the long, narrow ailerons, and 17 per cent for the short, wide ones. The large reduction with the short, wide ailerons is mainly due to the increase of the minimum drag coefficient. This increase could probably be largely eliminated by the use of an airfoil section with fair lines and a turned-up trailing edge over the portion of the span covered by the ailerons.

Rate of climb.—In order to establish a suitable criterion for the effect of the wing and the ailerons on the rate of climb of an airplane, the performance curves of a number of types and sizes of airplanes were calculated, and the relation of the maximum rate of climb to the lift and drag curves was studied. This investigation showed that the  $L/D$  at  $C_L=0.70$  gave a consistently reliable figure of merit for this purpose. All three sizes of ailerons, when rigged up 10°, gave values about 7 per cent higher than for the wings with the ailerons rigged at 0°.

##### LATERAL CONTROLLABILITY

Rolling criterion.—The rolling criterion upon which the control effectiveness of each of the aileron arrangements is judged is a figure of merit that is designed to

be proportional to the initial acceleration of the wing tip, following a deflection of the ailerons from neutral, regardless of the air speed or the wing plan form of an airplane. Expressed in coefficient form for a rectangular monoplane wing, the criterion becomes

$$RC = \frac{C_l}{C_L}$$

where  $C_l$  is the rolling-moment coefficient about the body axis due to the ailerons. The numerical value of this expression that has been found to represent satisfactory control conditions is approximately 0.075. A more detailed explanation of  $RC$  and its more general form which is applicable to any wing plan form is given in Part I.

The comparison of the ailerons on the basis of this criterion is given in Table VIII at four representative angles of attack; namely, 0°, 10°, 20°, and 30°. The first angle, 0°, represents the high-speed attitude;  $\alpha=10^\circ$  represents the highest angle of attack at which entirely satisfactory control with ordinary ailerons can be maintained;  $\alpha=20^\circ$  represents the condition of greatest instability in rolling, and is probably the greatest attainable angle of attack with most present-day airplanes in a steady glide; and finally,  $\alpha=30^\circ$  is given only for comparison with controls for possible future types of airplanes.

At  $\alpha=0^\circ$ , the rolling control produced by any of the aileron arrangements is much greater than necessary, it being even greater than for the corresponding arrangements with the ailerons rigged even with the wing when neutral.

At  $\alpha=10^\circ$ , the control is also greater for all three aileron sizes, with the ailerons deflected 25° up and 25° down, than for the corresponding arrangements with the original rigging. With the differential movements the control is about the same with both systems of rigging, and with the upward movement only, it is slightly lower with the ailerons rigged up 10°. By the simple expedient of changing slightly the assumed maximum deflection of any of these ailerons, they could be arranged to give the same maximum moment at  $\alpha=10^\circ$ , which would allow a more accurate comparison if such was desired.

At  $\alpha=20^\circ$ , which represents the region of greatest instability, all three aileron sizes and all movements give less control than the assumed satisfactory value, with the exception of the short, wide ailerons with the extreme differential movement. These give the satisfactory value of  $RC=0.075$ . As shown by Figure 5, however, the value of  $RC$  is slightly lower at the angle of attack for maximum lift coefficient than at either 10° or 20°. On the other hand, it reaches a peak value at  $\alpha=22^\circ$  which is 13 per cent higher than the assumed satisfactory value. The condition in which the values of  $RC$  became greater as the angle of attack was increased above the stall was true only for the

short, wide ailerons with at least a certain amount of differential movement. It will be noticed from Figure 5 that these ailerons with either differential movement or with up-only movement gave reasonably satisfactory control up to angles of attack  $5^\circ$  or  $6^\circ$  above the stall.

At  $\alpha=30^\circ$ , all of the ailerons gave very unsatisfactory control.

Lateral control with sideslip.—If a wing is yawed  $20^\circ$ , a rolling moment is set up that tends to raise the

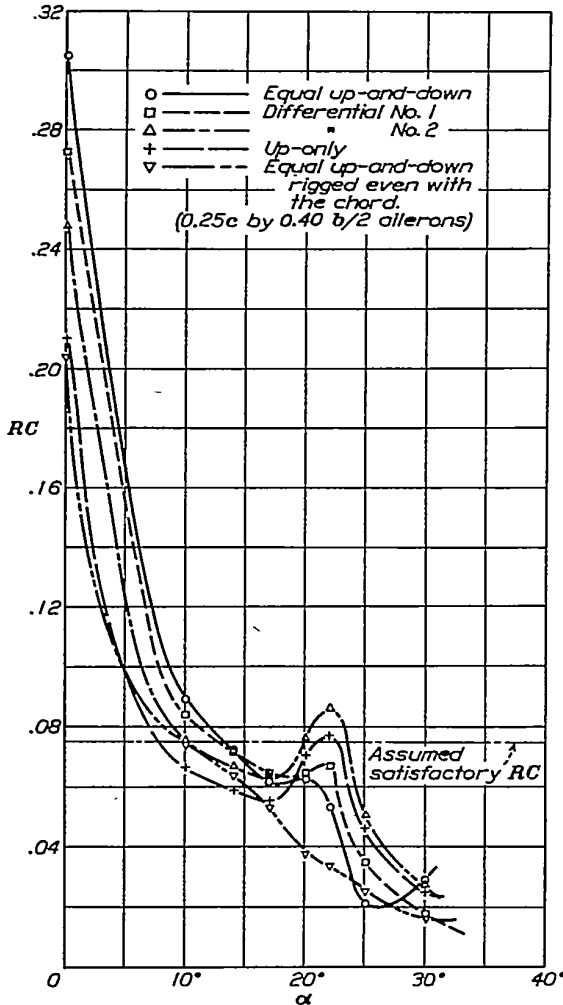

FIGURE 5.—Rolling criterion. 40 per cent chord by 30 per cent semispan ailerons with various movements. (Neutral position  $10^\circ$  up)

forward tip with a magnitude that is always greater at very high angles of attack than the available rolling moment due to conventional ailerons. The limiting angle of attack at which the ailerons can balance the rolling moment due to  $20^\circ$  yaw represents the greatest angle of attack that can be held in an average sideslip. This angle is tabulated for all aileron arrangements as a criterion of control with sideslip. The controllability obtained with the present aileron rigging was found to be slightly better than that with the original rigging. The best control against sideslip was obtained

by the short, wide ailerons with the extreme differential movement, with which an angle of attack of  $26^\circ$  was reached before the rolling moment due to yaw overpowered the rolling moment due to the ailerons.

Yawing moment due to ailerons.—The desirable yawing moment due to ailerons varies to some extent with the type of airplane that is being considered. For a highly maneuverable military or acrobatic machine, complete independence of the controls as they affect the turning moments about the various body axes is no doubt a desirable feature. On the other hand, for large transport airplanes or for machines to be operated by relatively inexperienced pilots, a favorable yawing moment of the proper magnitude would be an appreciable aid to safe flying. Finally, it is obvious that a yawing moment tending to turn the airplane out of its bank is never desirable under any circumstances. Any yawing tendency caused by the ailerons can be overcome only by the rudder, and the criterion used for it is simply the yawing-moment coefficient with respect to the body axes,  $C_n$ . The value of this coefficient on any particular airplane is approximately proportional to the rudder deflection required to overcome it regardless of the angle of attack or the air speed. It is, therefore, interesting to compare the yawing moments due to the ailerons with the maximum values of the yawing-moment coefficients obtained with average rudders, these being about 0.01 for the angles of attack below the stall and about 0.007 at an angle of attack of  $20^\circ$ .

At either the  $0^\circ$  or  $10^\circ$  angles of attack with the ailerons rigged  $10^\circ$  up when neutral, no adverse yawing moments of appreciable magnitude were given by any of the aileron sizes or movements. At the  $20^\circ$  and  $30^\circ$  angles of attack, some gave adverse yawing moments but they were small for both the medium and the short, wide ailerons, and were smaller than with the original rigging for the long, narrow ailerons. With any of the ailerons, the differential movements gave higher favorable and lower adverse yawing moments, the up-only movements giving no adverse yawing moments at any angle of attack for any of the three sizes. At angles of attack up to and including  $20^\circ$ , which covers the entire range that can be maintained in glides with most present-day conventional airplanes, no adverse yawing moments were given by the short, wide ailerons with either differential movement, or by the medium ailerons with the extreme differential. Further, no adverse yawing moments of serious magnitude were given by either the short, wide or the medium-sized ailerons with any deflection movement tried. The long, narrow ailerons, however, gave substantial adverse yawing moments at  $\alpha=20^\circ$  with all movements except the up-only.

The ailerons giving the smallest values of  $C_n$  throughout the entire usable range of angles of attack were the medium-sized ones with equal up-and-down deflection.

These were closely approached by the short, wide ailerons, also with equal up-and-down deflection.

#### LATERAL STABILITY

Angle of attack above which autorotation is self-starting.—This criterion is a measure of the range of angles of attack above which autorotation will start from an initial condition of practically zero rate of rotation. The limiting angle of attack was 19° for the long, narrow, and for the medium ailerons, and 20° for the short, wide ones, the value in each case being about 1° higher than with the original rigging.

Stability against rolling caused by gusts.—Test flights have shown that in severe gusts a rolling velocity such that  $\frac{p'b}{2V} = 0.05$  may be obtained. Consequently, the rolling moment of a wing due to rolling at this value of  $\frac{p'b}{2V}$  gives a measure of its stability characteristics in rough air. In the present case, the angle at which this rolling moment becomes zero is used as a more severe criterion than the previously mentioned angle at which autorotation is self-starting, to indicate the practical upper limit of the useful angle-of-attack range. With either 0° or 20° yaw, all of the present arrangements became unstable at angles of attack from 1° to 3° higher than with the original rigging.

The above criterion shows the critical range below which stability is such that any rolling is damped out, and above which instability exists. The last criterion, maximum  $C_x$ , indicates the degree of this instability. With both 0° and 20° yaw, all three sizes of ailerons gave somewhat lower values of maximum unstable  $C_x$  than with the original rigging.

#### CONTROL FORCE REQUIRED

A coefficient representing the force required on the control stick has been computed from the results of previous tests on hinge moments (references 1 and 4), in accordance with the following formula:

$$CF = \frac{F \times l}{q \times c \times S \times C_L}$$

where  $F$  is the control force required, and  $l$  represents the length of the control lever. As in the case of the rolling criterion, the  $C_L$  in the denominator gives the values of the coefficient the proper relation regardless of the angle of attack or the air speed, steady flight being assumed. Values of the control-force coefficient are given in Table VIII for the assumed maximum aileron deflection, the top of the control stick being given the same maximum travel in all cases.

The control forces with both ailerons rigged up 10° when neutral are appreciably greater for all of the ailerons tested than for the corresponding sizes and movements with the original rigging. In general, as was the case with the original rigging, the control force required is largest for the ailerons having the largest chord. It is about three times as great for the short,

wide ailerons as for the long, narrow ones, and is nearly twice as great for the short, wide ones as for the medium ones.

#### CONCLUSIONS

The following conclusions have been drawn in regard to the ordinary ailerons rigged up 10° when neutral:

(1) The short, wide ailerons with the extreme differential or the up-only movements were the only ones tested which gave the assumed satisfactory direct rolling control at angles of attack well above the stall (5° or 6° above). The rolling control with these ailerons, however, was slightly below the assumed satisfactory value just at the stall. It was better for the short, wide ailerons with the extreme differential movement than with any other aileron tested.

(2) At an angle of attack of 20°, the short, wide ailerons gave from 85 to 100 per cent of the assumed satisfactory direct rolling control with all four aileron movements; the medium-size ailerons gave in the neighborhood of 60 per cent, and the long, narrow ones in the neighborhood of 40 per cent of the assumed satisfactory value.

(3) Negligibly small yawing moments (body axes), at all angles of attack which can be maintained by conventional airplanes, were given by the medium-sized ailerons with equal up-and-down deflection.

(4) Large favorable yawing moments (body axes) and no adverse ones with any portion of the total deflection were given at all angles of attack by each of the three sizes of ailerons with up-only movement; by the short, wide ailerons with either differential movement; and by the medium-sized ailerons with the extreme differential movement.

(5) The degree of the lateral instability as shown by the maximum rolling moment due to rolling is somewhat less with both ailerons rigged up 10° than with the ailerons rigged even with the wing.

LANGLEY MEMORIAL AERONAUTICAL LABORATORY,  
NATIONAL ADVISORY COMMITTEE FOR AERONAUTICS,  
LANGLEY FIELD, VA., February 5, 1932.

#### REFERENCES

1. Weick, Fred E., and Wenzinger, Carl J.: Wind-Tunnel Research Comparing Lateral Control Devices, Particularly at High Angles of Attack. I—Ordinary Ailerons on Rectangular Wings. T. R. No. 419, N. A. C. A., 1932.
2. Weick, Fred E., and Noyes, Richard W.: Wind-Tunnel Research Comparing Lateral Control Devices, Particularly at High Angles of Attack. II—Slotted Ailerons and Frise Ailerons. T. R. No. 422, N. A. C. A., 1932.
3. Harris, Thomas A.: The 7 by 10 Foot Wind Tunnel of the National Advisory Committee for Aeronautics. T. R. No. 412, N. A. C. A., 1932.
4. Monish, B. H.: Effect of Variation of Chord and Span of Ailerons on Hinge Moments at Several Angles of Pitch. T. R. No. 370, N. A. C. A., 1930.

TABLE II

FORCE TEST. 10 BY 60 INCH CLARK Y WING WITH ORDINARY 15 PER CENT *c* BY 60 PER CENT *b*/2 AILERONS

R. N.=609,000. YAW=0°. VELOCITY=80 M. P. H.

(Neutral with right and left 10° up)

$\alpha$	$C_L$	$C_D$
-2°	0.091	0.016
6.6°	.700	.041
15°	1.152	.114
16°	1.147	.131
17°	1.145	.145
18°	1.145	.163
20°	.945	.259
30°	.740	.470

TABLE III

ROTATION TESTS. 10 BY 60 INCH CLARK Y WING WITH ORDINARY 15 PER CENT *c* BY 60 PER CENT *b*/2 AILERONS

R. N.=609,000. YAW=0° AND -20°. VELOCITY=80 M. P. H.

(Neutral with right and left 10° up)

$C_L$  is given for forced rotation at  $\frac{p'b}{2V} = 0.05$  (+) adding rotation  
 (-) damping rotation  
 $\frac{p'b}{2V}$  values are for free rotation.

$\alpha$		0°	12°	14°	16°	18°	19°	20°	21°	22°	25°	26°	28°	30°	32°	35°	37°	39°	40°
Yaw=0°																			
(+) Rotation (clockwise)	$\frac{C_L}{\frac{p'b}{2V}}$	-0.0190	-0.0198	-0.0160	-0.0115	-0.0020	0.007	0.0200	0.0340	0.0250	0.0030			0.0096					0.0000
(-) Rotation (counter-clockwise)	$\frac{C_L}{\frac{p'b}{2V}}$	-0.0235	-0.0214	-0.0166	-0.0100	-0.0040	0.0100	0.0205	0.0250	0.0210	0.0040			-0.0075					-0.0005
Yaw=-20°																			
(+) Rotation (clockwise)	$C_L$	-0.0210	-0.0295	-0.0350	-0.0450	-0.0580	-0.0645	-0.0740	-0.0730	-0.0785	-0.0640			-0.0720					-0.0530
(-) Rotation (counter-clockwise)	$C_L$	-0.0183	-0.0048	0.0042	0.0170	0.0352	0.0452	0.0737	0.0822	0.0842	0.0853			0.0777					0.0467

\* Not self-starting.

TABLE IV

FORCE TEST. 10 BY 60 INCH CLARK Y WING WITH ORDINARY 25 PER CENT *c* BY 40 PER CENT *b*/2 AILERONS

R.N.=609,000. YAW=0°. VELOCITY=80 M. P. H.

(Neutral with right and left 10° up)

$\alpha$	$C_L$	$C_D$
-2°	0.110	0.017
6.3°	.700	.041
15°	1.190	.114
16°	1.192	.129
17°	1.195	.148
18°	1.205	.165
19°	1.193	.180
20°	1.140	.210
30°	.753	.472



TABLE V

ROTATION TESTS. 10 BY 60 INCH CLARK Y WING WITH ORDINARY 25 PER CENT *c* BY 40 PER CENT *b*/2 AILERONS

R. N.=609,000. YAW=0° AND -20°. VELOCITY=80 M. P. H.

(Neutral with right and left 10° up)  
*C<sub>A</sub>* is given for forced rotation at  $\frac{p'b}{2V}=0.05$  { (+) aiding rotation  
 (-) damping rotation  
 $\frac{p'b}{2V}$  values are for free rotation.

$\alpha$	0°	10°	12°	14°	16°	18°	19°	20°	21°	22°	23°	24°	25°	26°	27°	30°	40°	
Yaw=0°																		
(+) Rotation (clockwise)	$\frac{C_A}{\frac{p'b}{2V}}$	-0.0200	-0.0230	-0.0220	-0.0200	-0.0130	-0.0055	-0.0010	0.0250	0.0345	0.0400	0.0450	0.0400	0.332	0.364	0.348	-0.0020	-0.0020
(-) Rotation (counterclockwise)	$\frac{C_A}{\frac{p'b}{2V}}$	-0.0190	-0.0210	-0.0200	-0.0180	-0.0110	-0.0035	0.0000	0.0295	0.0355	0.0190	0.0150	0.0065	0.302	0.323	0.326	-0.0015	-0.0010
Yaw=-20°																		
(+) Rotation (clockwise)	<i>C<sub>A</sub></i>	-0.0210	-0.0290	-0.0310	-0.0360	-0.0440	-0.0570	-0.0760	-0.0860	-0.0720	-0.0770	-0.0830	-0.0870			-0.0800	-0.0570	
(-) Rotation (counterclockwise)	<i>C<sub>A</sub></i>	-0.0170	-0.0085	-0.0040	0.0010	0.0140	0.0340	0.0710	0.0785	0.0840	0.0880	0.0830	0.0830			0.0800	0.0520	

\* Not self-starting.

TABLE VI

FORCE TEST. 10 BY 60 INCH CLARK Y WING WITH ORDINARY 40 PER CENT *c* BY 30 PER CENT *b*/2 AILERONS

R. N.=609,000. YAW=0°. VELOCITY=80 M. P. H.

(Neutral with right and left 10° up)

$\alpha$	<i>C<sub>L</sub></i>	<i>C<sub>D</sub></i>
-2°	0.125	0.018
6.1°	0.700	0.041
16°	1.172	0.131
17°	1.173	0.148
18°	1.173	0.167
19°	1.170	0.184
20°	1.013	0.242
30°	0.762	0.467

TABLE VII

ROTATION TESTS. 10 BY 60 INCH CLARK Y WING WITH ORDINARY 40 PER CENT *c* BY 30 PER CENT *b*/2 AILERONS

R. N.=609,000. YAW=0° AND -20°. VELOCITY=80 M. P. H.

(Neutral with right and left 10° up)

*C<sub>A</sub>* is given for forced rotation at  $\frac{p'b}{2V}=0.05$  { (+) aiding rotation  
 (-) damping rotation  
 $\frac{p'b}{2V}$  values are for free rotation.

$\alpha$	0°	12°	14°	16°	18°	19°	20°	21°	22°	23°	25°	28°	30°	40°
Yaw=0°														
(+) Rotation (clockwise)	$\frac{C_A}{\frac{p'b}{2V}}$	-0.0203	-0.0213	-0.0178	-0.0068	-0.0018	0.0002	0.0127	0.0047	-0.0013	-0.0108	-0.0053	0.0002	
(-) Rotation (counterclockwise)	$\frac{C_A}{\frac{p'b}{2V}}$	-0.0205	-0.0205	-0.0165	-0.0090	-0.0070	-0.0060	0.0145	0.0150	0.0145	0.0140	0.0140	0.0000	
Yaw=-20°														
(+) Rotation (clockwise)	<i>C<sub>A</sub></i>	-0.0260	-0.0350	-0.0410	-0.0510	-0.0565	-0.0505	-0.0450	-0.0505	-0.0535	-0.0605	-0.0580	-0.0480	
(-) Rotation (counterclockwise)	<i>C<sub>A</sub></i>	-0.0175	-0.0040	0.0085	0.0270	0.0455	0.0530	0.0640	0.0715	0.0690	0.0670	0.0590	0.0400	

TABLE VIII  
CRITERIONS SHOWING RELATIVE MERITS OFAILERONS

Subject	Criterion	Plain ailerons rigged 10° up 15 per cent c by 60 per cent b/2				Plain ailerons rigged 10° up 25 per cent c by 40 per cent b/2				Plain ailerons rigged 10° up 40 per cent c by 30 per cent b/2			
		Stand-ard 25° up 25° down	Differ-ential No. 1 35° up 15° down	Differ-ential No. 2 50° up 7° down	Up only 60° up 60° down	Stand-ard 25° up 25° down	Differ-ential No. 1 35° up 15° down	Differ-ential No. 2 50° up 7° down	Up only 60° up 60° down	Stand-ard 25° up 25° down	Differ-ential No. 1 35° up 15° down	Differ-ential No. 2 50° up 7° down	Up only 60° up 60° down
Wing area or minimum speed.	Maximum $C_L$	1.152	1.152	1.152	1.152	1.205	1.205	1.205	1.205	1.173	1.173	1.173	1.173
Speed range.	Max $C_L$ /Min $C_D$	72.0	72.0	72.0	72.0	70.5	70.5	70.5	70.5	65.2	65.2	65.2	65.2
Rate of climb.	$L/D$ at $C_L=0.70$	17.1	17.1	17.1	17.1	17.1	17.1	17.1	17.1	17.1	17.1	17.1	17.1
Lateral control-lability.	RC $\alpha=0^\circ$	.310	.291	.266	.217	.249	.231	.220	.185	.305	.273	.248	.210
	RC $\alpha=10^\circ$	.079	.070	.063	.052	.081	.077	.075	.063	.089	.084	.076	.060
	RC $\alpha=20^\circ$	.022	.019	.030	.023	.044	.041	.047	.046	.063	.064	.076	.070
Lateral control with sideslip.	RC $\alpha=30^\circ$	.031	.009	.009	.001	.005	.003	.004	.007	.029	.017	.007	.025
	Maximum $\alpha$ at which ailerons will balance $C_l'$ due to 20° yaw.	19°	19°	19°	18°	20°	21°	23°	22°	20°	22°	26°	23°
	$C_n$ $\alpha=0^\circ$	-.001	-.005	.010	.014	.002	.009	.016	.020	.005	.013	.021	.020
Yawing moment due to ailerons, (+) favorable, (-) unfavorable.	$C_n$ $\alpha=10^\circ$	-.002	-.007	.012	.015	.004	.011	.018	.022	.005	.016	.026	.031
	$C_n$ $\alpha=20^\circ$	-.008	-.004	.005	.009	-.002	.008	.014	.017	.001	.015	.030	.037
	$C_n$ $\alpha=30^\circ$	-.001	-.002	.002	.003	-.005	-.001	-.002	.004	-.001	.002	.009	.014
	$C_n$ $\alpha=30^\circ$	-.001	-.001	-.002	-.002	-.002	-.002	-.002	-.004	-.004	-.004	-.001	-.001
Lateral stability ( $\delta_A=0^\circ$ ).	$\alpha$ for initial instability in rolling.	19.0°	19.0°	19.0°	19.0°	19.0°	19.0°	19.0°	19.0°	20.0°	20.0°	20.0°	20.0°
	$\alpha$ for initial instability at $\frac{p'b}{2V}=0.05$ ; yaw=0°.	18.5°	18.5°	18.5°	18.5°	18.5°	18.5°	18.5°	18.5°	19.0°	19.0°	19.0°	19.0°
	$\alpha$ for initial instability at $\frac{p'b}{2V}=0.05$ ; yaw=20°.	13.0°	13.0°	13.0°	13.0°	13.5°	13.5°	13.5°	13.5°	13.0°	13.0°	13.0°	13.0°
	Maximum unstable $C_n$ ; yaw=0°.	.025	.025	.025	.025	.045	.045	.045	.045	.015	.015	.015	.015
	Maximum unstable $C_n$ ; yaw=20°.	.085	.035	.085	.085	.088	.088	.088	.088	.072	.072	.072	.072
Control force required.	CF $\alpha=0^\circ$	.016	.019	.027	.031	.021	.029	.045	.054	.041	.059	.097	.124
	CF $\alpha=10^\circ$	.004	.004	.005	.007	.007	.007	.009	.012	.011	.010	.012	.018
	CF $\alpha=20^\circ$	.004	.002	.002	.003	.003	.003	.003	.003	.009	.005	.006	.006
	CF $\alpha=30^\circ$	.004	.002	.003	.003	.007	.004	.004	.004	.012	.006	.008	.008

\* to  $\delta$  where the maximum yawing moments occurred below maximum deflection, the letters indicate the deflection of the up aileron as follows:  $\delta=10^\circ$ ,  $\delta=20^\circ$ ,  $\delta=30^\circ$ .  
 $\delta$  RC has a minimum value of 0.083 at  $\alpha=17^\circ$  and a maximum of 0.036 at  $\alpha=22^\circ$ .  
 $\delta$  RC=0.055 at  $\alpha=17^\circ$  and 0.077 at  $\alpha=22^\circ$ .

TABLE IX  
CRITERIONS SHOWING RELATIVE MERITS OFAILERONS

Subject	Criterion	Plain ailerons 15 per cent c by 60 per cent b/2					Plain ailerons 25 per cent c by 40 per cent b/2 (assumed standard size)					Plain ailerons 40 per cent c by 30 per cent b/2				
		Stand-ard 25° up, 25° down	Differ-ential, No. 1, 35° up, 15° down	Differ-ential, No. 2, 50° up, 7° down	Up only, 60°	Float-ing, 50° dif-ference	Stand-ard 25° up, 25° down	Differ-ential, No. 1, 35° up, 15° down	Differ-ential, No. 2, 50° up, 7° down	Up only, 60°	Float-ing, 50° dif-ference	Stand-ard 25° up, 25° down	Differ-ential, No. 1, 35° up, 15° down	Differ-ential, No. 2, 50° up, 7° down	Up only, 60°	Float-ing, 50° dif-ference
Wing area or minimum speed.	Maximum $C_L$	1.222	1.222	1.222	1.222	1.140	1.270	1.270	1.270	1.168	1.258	1.258	1.258	1.258	1.083	
Speed range.	Max $C_L$ /Min $C_D$	78.4	78.4	78.4	78.4	76.0	79.4	79.4	79.4	77.8	78.5	78.5	78.5	78.5	57.0	
Rate of climb.	$L/D$ at $C_L=0.70$	15.9	15.9	15.9	15.9	16.3	15.9	15.9	15.9	16.3	15.9	15.9	15.9	15.9	14.9	
Lateral control-lability.	RC $\alpha=0^\circ$	.218	.214	.233	.203	.220	.204	.202	.214	.196	.243	.226	.234	.226	.202	
	RC $\alpha=10^\circ$	.071	.071	.075	.084	.073	.076	.074	.072	.083	.078	.084	.083	.078	.101	
	RC $\alpha=20^\circ$	.020	.018	.032	.026	.021	.038	.051	.055	.054	.035	.046	.058	.073	.063	
Lateral control with sideslip.	RC $\alpha=30^\circ$	.054	.027	.013	.009	-.015	.017	.005	.002	-.018	.019	.025	.028	.022	.025	
	Maximum $\alpha$ at which ailerons will balance $C_l'$ due to 20° yaw.	19°	18°	19°	19°	18°	20°	20°	21°	22°	19°	19°	20°	22°	24°	
	$C_n$ $\alpha=0^\circ$	-.006	-.003	-.003	-.001	-.003	-.007	-.003	-.002	-.010	-.016	-.002	-.016	-.021	.002	
Yawing moment due to ailerons, (+) favorable, (-) unfavorable.	$C_n$ $\alpha=10^\circ$	-.002	-.002	-.009	-.012	-.004	-.013	-.004	-.018	-.002	-.007	-.006	-.020	-.020	.009	
	$C_n$ $\alpha=20^\circ$	-.003	-.002	-.001	-.001	-.004	-.002	-.001	-.008	-.013	-.007	-.003	-.002	-.019	.010	
	$C_n$ $\alpha=30^\circ$	-.012	-.009	-.008	-.004	-.003	-.010	-.007	-.006	-.003	-.010	-.008	-.007	-.003	.003	
	$C_n$ $\alpha=30^\circ$	-.002	-.003	-.002	-.001	-.003	-.008	-.003	-.007	-.004	-.012	-.009	-.005	-.002	.009	
Lateral stability ( $\delta_A=0^\circ$ ).	$\alpha$ for initial instability in rolling.	18°	18°	18°	18°	19°	18°	18°	18°	21°	18°	18°	18°	18°	19°	
	$\alpha$ for initial instability at $\frac{p'b}{2V}=0.05$ Yaw=0°.	17°	17°	17°	17°	19°	17°	17°	17°	21°	17°	17°	17°	17°	18°	
	$\alpha$ for initial instability at $\frac{p'b}{2V}=0.05$ Yaw=20°.	10°	10°	10°	10°	13°	11°	11°	11°	15°	12°	12°	12°	12°	15°	
	Maximum unstable $C_n$ . Yaw=0°.	.028	.028	.028	.028	.024	.048	.048	.048	.048	.016	.022	.022	.022	.022	
	Maximum unstable $C_n$ . Yaw=20°.	.087	.087	.087	.087	.080	.093	.093	.093	.093	.071	.085	.085	.085	.047	
Control force required.	CF $\alpha=0^\circ$	.010	.012	.015	.021	.012	.017	.019	.028	.041	.022	.030	.032	.052	.046	
	CF $\alpha=10^\circ$	.003	.002	.003	.006	.004	.006	.005	.005	.010	.007	.010	.007	.007	.014	
	CF $\alpha=20^\circ$	.003	.002	.002	.003	.003	.006	.003	.003	.009	.009	.009	.004	.004	.012	
	CF $\alpha=30^\circ$	.003	.002	.002	.003	.007	.003	.003	.003	.011	.004	.004	.004	.004	.012	

\* to  $\delta$  where the maximum yawing moment occurred below maximum deflection, the letters indicate the deflection of the up-aileron as follows:  $\delta=10^\circ$ ,  $\delta=15^\circ$ ,  $\delta=20^\circ$ .  
 $\delta=25^\circ$ ,  $\delta=30^\circ$ ,  $\delta=40^\circ$ .  
 $\delta$  RC has a minimum value of 0.066 at  $\alpha=17^\circ$  and a maximum of 0.079 at  $\alpha=22^\circ$ .  
 $\delta$  RC=0.064 at  $\alpha=17^\circ$  and 0.094 at  $\alpha=22^\circ$ .